

CE

PL2000

PORTABLE LATHE

OPERATING MANUAL

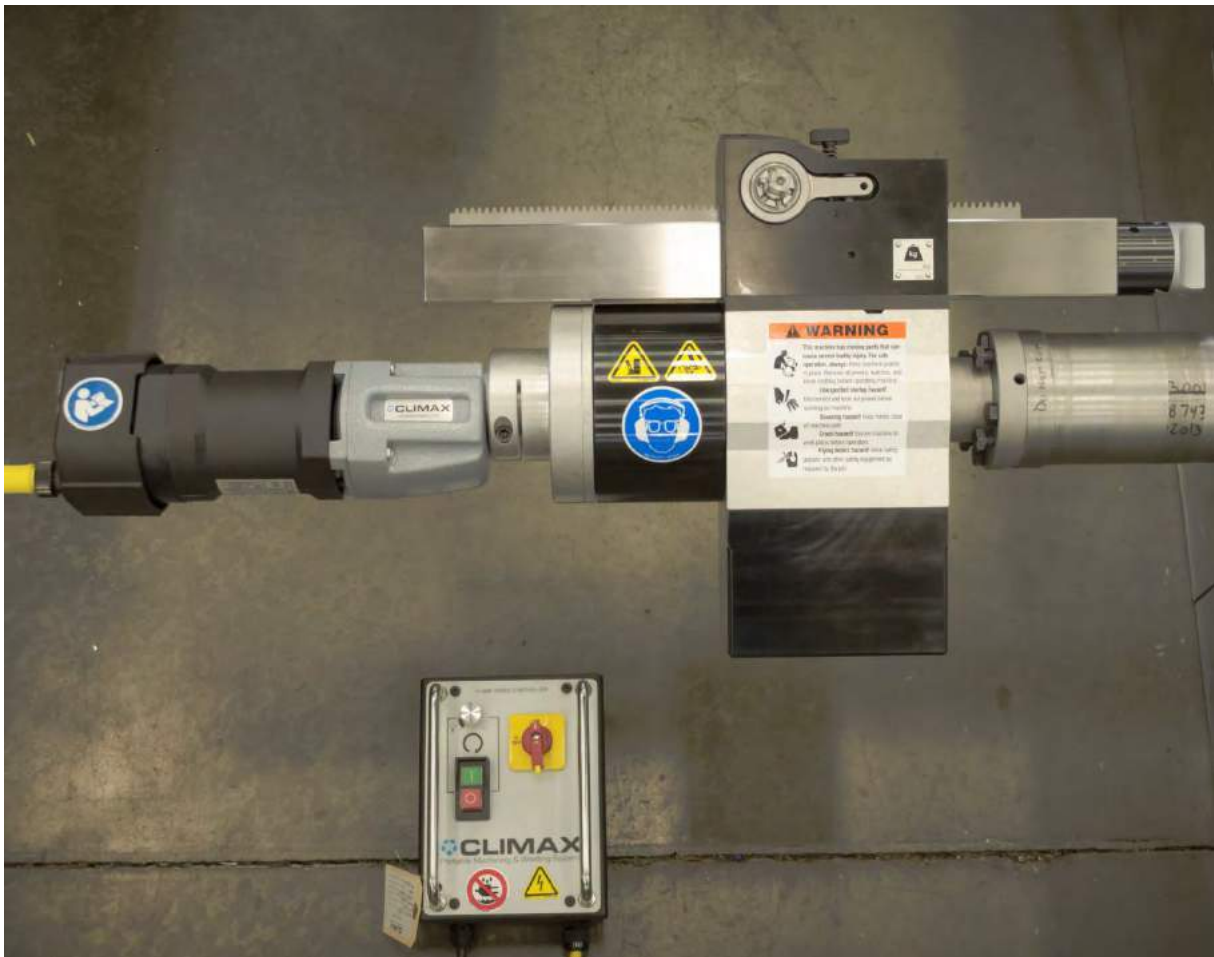

 **CLIMAX**
Portable Machining & Welding Systems

©2019 CLIMAX or its subsidiaries.

All rights reserved.

Except as expressly provided herein, no part of this manual may be reproduced, copied, transmitted, disseminated, downloaded, or stored in any storage medium, without the express prior written consent of CLIMAX. CLIMAX hereby grants permission to download a single copy of this manual and of any revision hereto onto an electronic storage medium to be viewed and to print one copy of this manual or any revision hereto, provided that such electronic or printed copy of this manual or revision must contain the complete text of this copyright notice and provided further that any unauthorized commercial distribution of this manual or any revision hereto is prohibited.

At CLIMAX, we value your opinion.

For comments or questions about this manual or other CLIMAX documentation, please e-mail documentation@cpmt.com.

For comments or questions about CLIMAX products or services, please call CLIMAX or e-mail info@cpmt.com. For quick and accurate service, please provide your representative with the following:

- Your name
- Shipping address
- Telephone number
- Machine model
- Serial number (if applicable)
- Date of purchase

CLIMAX World Headquarters

2712 East 2nd Street Newberg, Oregon 97132
USA

Telephone (worldwide): +1-503-538-2815
Toll-free (North America): 1-800-333-8311
Fax: 503-538-7600

CLIMAX / H&S Tool (UK Headquarters)

Unit 7 Castlehill Industrial Estate Bredbury
Industrial Park Horsfield Way
Stockport SK6 2SU, UK Telephone: +44 (0) 161-406-1720

CLIMAX / H&S Tool (Asia Pacific Headquarters)

316 Tanglin Road #02-01
Singapore 247978
Telephone: +65 9647-2289
Fax: +65 6801-0699

H&S Tool World Headquarters

715 Weber Dr.
Wadsworth, OH 44281 USA

Telephone: +1-330-336-4550
Fax: 1-330-336-9159
hstool.com

CLIMAX / H&S Tool (European Headquarters)

Am Langen
Graben 8 52353
Düren, Germany
Telephone: +49 24-219-1770
E-mail: CLIMAXEurope@cpmt.com

CLIMAX / H&S Tool (Middle East Headquarters)

Warehouse #5, Plot:
369 272 Um Sequim
Road
Al Quoz 4
PO Box 414 084
Dubai, UAE
Telephone: +971 04-321-0328

CLIMAX WORLDWIDE LOCATIONS

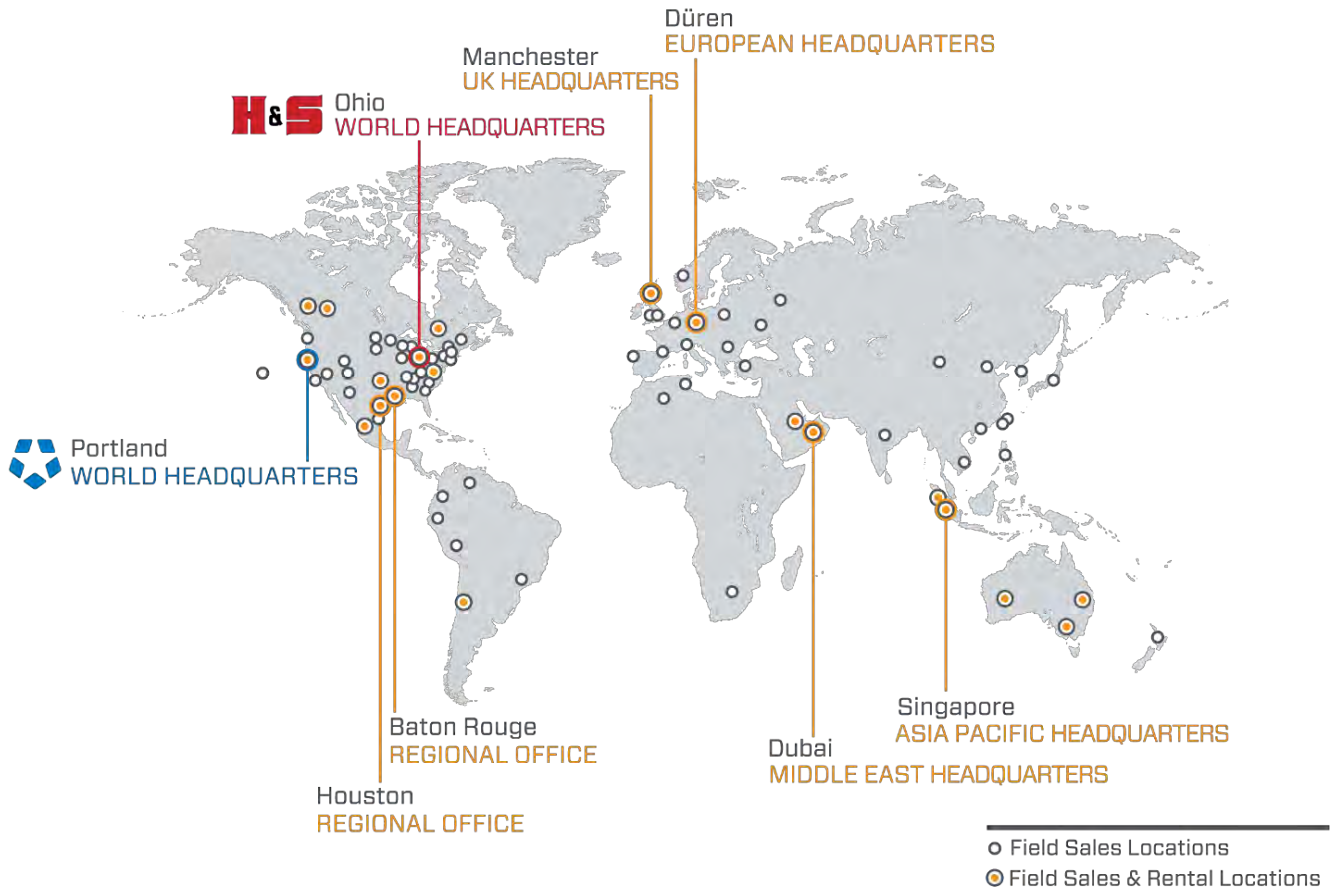

LIMITED WARRANTY

CLIMAX Portable Machine Tools, Inc. (hereafter referred to as “CLIMAX”) warrants that all new machines are free from defects in materials and workmanship. This warranty is available to the original purchaser for a period of one year after delivery. If the original purchaser finds any defect in materials or workmanship within the warranty period, the original purchaser should contact its factory representative and return the entire machine, shipping prepaid, to the factory. CLIMAX will, at its option, either repair or replace the defective machine at no charge and will return the machine with shipping prepaid.

CLIMAX warrants that all parts are free from defects in materials and workmanship, and that all labor has been performed properly. This warranty is available to the customer purchasing parts or labor for a period of 90 days after delivery of the part or repaired machine or 180 days on used machines and components. If the customer purchasing parts or labor finds any defect in materials or workmanship within the warranty period, the purchaser should contact its factory representative and return the part or repaired machine, shipping prepaid, to the factory. CLIMAX will, at its option, either repair or replace the defective part and/ or correct any defect in the labor performed, both at no charge, and return the part or repaired machine shipping prepaid.

These warranties do not apply to the following:

- Damage after the date of shipment not caused by defects in materials or workmanship
- Damage caused by improper or inadequate machine maintenance
- Damage caused by unauthorized machine modification or repair
- Damage caused by machine abuse
- Damage caused by using the machine beyond its rated capacity

All other warranties, express or implied, including without limitation the warranties of merchantability and fitness for a particular purpose are disclaimed and excluded.

Terms of sale

Be sure to review the terms of sale which appear on the reverse side of your invoice. These terms control and limit your rights with respect to the goods purchased from CLIMAX.

About this manual

CLIMAX provides the contents of this manual in good faith as a guideline to the operator. CLIMAX cannot guarantee that the information contained in this manual is correct for applications other than the application described in this manual. Product specifications are subject to change without notice.

CE DOCUMENTATION

Climax Portable Machine Tools, Inc.

Effective Date: June 6, 2011

Declaration of Conformity



Manufacturer Address:
Climax Portable Machine Tools, Inc.
2712 E. Second St., P.O. Box 1210
Newberg, Oregon
USA 97132-8210
1-800-333-8311 - www.cpmt.com

EC Authorized Representative:
Climax GmbH
Am Langen Graben 8
52353 Düren / Germany
Tel.: (+49)(0) - 2421 / 9177 - 0

Climax GmbH is authorized to compile a technical file for this product.

We hereby declare that the machinery described:

Make: Portable Lathe
Models: PL2000, PL3000, PL4000
Serial Numbers: 11016661 - 15128700

Is in compliance with the following directives:

2006/42/EC - Machinery

Compliance with the relevant EHSR of the above directives is by application of the following referenced harmonized standards:

EN 349, EN 982 + A1, EN 983 + A1, EN 3744, EN 11201, EN 12100-1, EN 12100-2, EN 13128 + A2, EN 13732-1, EN 13849-1, EN 14121-1, EN 60204-1, EN 55011, EN 55022, EN 61000-4-3, EN 61000-4-6

VP - Operations
Climax Portable Machine Tools, Inc.
2712 E. Second St., Newberg, Oregon
USA 97132-8210

Signed in Newberg, Oregon 97132-8210 USA on:

DATE

6/6/2011

TABLE OF CONTENTS

1	OVERVIEW	1
1.1	LIMITED WARRANTY	ERROR! BOOKMARK NOT DEFINED.
1.2	HOW TO USE THIS MANUAL	1
1.2.1	Alerts	1
1.3	SAFETY PRECAUTIONS	2
2	CE	4
2.1	AUDIBLE NOISE LEVELS	4
2.2	WARNING LABELS	4
2.3	MACHINE LOCK-OUT	6
3	INTRODUCTION	7
3.1	ABOUT THIS MANUAL	7
3.2	ABOUT THE CLIMAX MODEL PL2000 PORTABLE LATHE	7
3.3	ELECTRIC LATHE	8
3.4	PNEUMATIC LATHE	10
4	SETUP	12
4.1	RECEIPT AND INSPECTION	12
4.2	PREPARING THE MOUNTING FLANGE	12
4.3	CENTERING THE MACHINE	13
4.4	MOTOR MOUNTING	13
4.4.1	Electric motor mounting	13
4.4.2	Air motor mounting	15
4.5	AIR POWER CONNECTION	16
4.5.1	To start the machine:	17
4.5.2	To stop the machine:	17
4.6	TOOL BIT PREPARATION	17
4.7	MANUAL AXIAL FEED	20
4.7.1	Setting rotational speed	20
4.7.2	Electric speed adjustment	20
4.7.3	Pneumatic speed adjustment	20
5	OPERATION	21
5.1	PRE-START CHECKS	21
5.1.1	General pre-start checks	21
5.1.2	Electric lathe pre-start checks	21
5.1.3	Pneumatic lathe pre-start checks	21
5.2	OPERATION	22
5.3	TAPER ADJUSTMENT	23
5.4	SINGLE BOLT MOUNTING ADAPTER	23
5.5	SHAFT POLISHING	23
5.6	SETTING THE ABRASIVE BELT HOLDER	24
5.7	SPOT POLISHING	24
5.8	POLISHING THE ENTIRE SHAFT	24
6	DISASSEMBLY	25
7	MAINTENANCE	26
7.1	RECOMMENDED LUBRICANTS	26

7.2	MAIN BODY	26
7.3	MOUNTING FLANGE	26
7.4	TURNING BAR ASSEMBLY	26
7.5	ELECTRIC MOTOR	26
7.6	AIR MOTOR AND PNEUMATIC CONDITIONING UNIT.....	27
7.7	PLANETARY HOUSING.....	27
8	STORAGE.....	28
8.2	LIST OF EXPLODED VIEWS AND PARTS.....	30

LIST OF FIGURES

FIGURE 1 – ELECTRIC PORTABLE LATHE.....	8
FIGURE 2 – CONTROLLER 10 AMP 230V 50/60 HZ P/N 79218	9
FIGURE 3 – PNEUMATIC PORTABLE LATHE (YOUR CONDITIONG UNIT MAY VARY FROM THE ILLUSTRATION).	10
FIGURE 4 – (1) FEED RATE KNOB: CONTINUOUSLY VARIABLE FROM 0–0.025" (0–0.635 MM) PER REVOLUTION. (2) CRITERION STYLE TOOL HEAD: (3) FEED <i>ENGAGEMENT</i> SHAFT: USE WITH THE HAND CRANK FOR MANUAL POSITIONING.....	11
FIGURE 5 – ELECTRIC PORTABLE LATHE CLEARANCE DIMENSIONS (INCHES/MM)	14
FIGURE 6 – PNEUMATIC PORTABLE LATHE CLEARANCE DIMENSIONS (INCHES/MM)	15
FIGURE 7- LOCKOUT VALVE	16
FIGURE 8 – TOOL BIT GEOMETRY - INCH (MM).....	19
FIGURE 9 – P/N 31594 BAR TURNING SUPPORT FEED ASSY	31
FIGURE 10 – P/N 31594 BAR TURNING SUPPORT FEED ASSY PARTS LIST	32
FIGURE 11 – P/N 30333 ASSY PNEUMATIC POWER MODULE PL2000.....	33
FIGURE 12 – P/N 78264 PNEUMATIC CONDITIONING UNIT 1/2 IN LOW PRES.	34
FIGURE 13 – P/N78264 PNEUMATIC CONDITIONING UNIT 1/2 IN LOW PRES.PARTS LIST.....	35
FIGURE 14 – P/N78264 PNEUMATIC CONDITIONING UNIT 1/2 IN LOW PRES. DROPOUT SCHEMATIC.....	36
FIGURE 15 – P/N 29998 ASSY PNEUMATIC PL2000	37
FIGURE 16 – P/N 31586 ASSY MAIN BODY 2 ND PL2000	38
FIGURE 17 – P/N 31590 SPACER ASSY 5-9 IN DIAMETER	39
FIGURE 18 -- CONTROLLER SCHEMATIC 10 AMP 230 V 50/60 HZ CE 79218.....	40
FIGURE 19 – P/N 79218 CONTROLLER 10 AMP 230 V 50/60 HZ CE.....	41
FIGURE 20 – P/N 79218 CONTROLLER 10 AMP 230 V 50/60 HZ CE MULTIPLE MODEL	42
FIGURE 21 – P/N 79218 CONTROLLER 10 AMP 230 V 50/60 HZ CE MULTIPLE MODEL PARTS LIST.....	43
FIGURE 22 – P/N 30572 SINGLE BOLT ADAPTER ASSY	44
FIGURE 23 – P/N 30407 INDICATOR ASSY PL2000	45
FIGURE 24 – P/N 31585 ASSY MAIN BODY & BAR ASSY 2 ND PL2000	46
FIGURE 25 – P/N 30309 DRIVE ROTATIONAL PL2000 ELECTRIC 120V AND P/N 30816 DRIVE ROTATIONAL PL2000 230V.....	47
FIGURE 26 – P/N 31584 MODEL PL2000 PORTABLE LATE AIR 2 ND	48

LIST OF TABLES

TABLE 1. RISK ASSESSMENT CHECKLIST BEFORE SET-UP	3
TABLE 2. RISK ASSESSMENT CHECKLIST AFTER SET-UP.....	3
TABLE 3 – DESCRIPTION OF LABELS	4
TABLE 4 – RECCOMENDED LUBRICANTS	26

1 OVERVIEW

1.1 How to Use This Manual

1.1.1 Alerts

Pay careful attention to the alerts appearing in this manual. Alert types are defined in the following examples.

DANGER

concerns a condition, procedure, or practice that, if not avoided or strictly observed, **WILL** result in injury or loss of life.

WARNING

concerns a condition, procedure, or practice that, if not avoided or strictly observed, **COULD** result in injury or loss of life.

CAUTION

concerns a condition, procedure, or practice that, if not avoided or strictly observed, could result in minor or moderate injury.

NOTICE

concerns a condition, procedure, or practice worthy of special attention.

TIP:

A tip provides additional information that can aid in completion of a task.

1.2 Safety Precautions

Climax Portable Machining and Welding Systems leads the way in promoting the safe use of portable machine tools. Safety is a joint effort. You, the machine operator, must do your part by being aware of your work environment and closely following the operating procedures and safety precautions contained in this manual, as well as your employer's safety guidelines.

Observe the following safety precautions when operating or working around the machine.

Training – Before operating this or any machine tool, you should receive instruction from a qualified trainer. Contact Climax for machine-specific training information.

Intended Use – Use this machine in accordance with the instructions and precautions in this manual. Do not use this machine for any purpose other than its intended use as described in this manual.

Personal Protective Equipment – Always wear the appropriate personal protective gear when operating this or any other machine tool. Eye and ear protection are required when operating or working around the machine. Flame-resistant clothing with long sleeves and legs is recommended when operating the machine, as hot flying chips from the workpiece may burn or cut bare skin.

Work Area – Keep the work area around the machine clear of clutter. Keep all cords and hoses away from the work area when operating the machine.

Moving Parts – Except for operating controls, avoid contact with moving parts by hands or tools during machine operation. Secure hair, clothing, jewelry, and pocket items to prevent them from becoming entangled in moving parts.

1.3 Risk assessment and hazard mitigation

Machine Tools are specifically designed to perform precise material-removal operations.

Stationary Machine Tools include lathes and milling machines and are typically found in a machine shop. They are mounted in a fixed location during operation and are considered to be a complete, self-contained machine. Stationary Machine Tools achieve the rigidity needed to accomplish material-removal operations from the structure that is an integral part of the machine tool.

In contrast, Portable Machine Tools are designed for on-site machining applications. They typically attach directly to the workpiece itself, or to an adjacent structure, and achieve their rigidity from the structure to which it is attached. The design intent is that the Portable Machine Tool and the structure attached to it become one complete machine during the material-removal process.

To achieve the intended results and to promote safety, the operator must understand and follow the design intent, set-up, and operation practices that are unique to Portable Machine Tools.

The operator must perform an overall review and on-site risk assessment of the intended application. Due to the unique nature of portable machining applications, identifying one or more hazards that must be addressed is typical.

When performing the on-site risk assessment, it is important to consider the Portable Machine Tool and the workpiece as a whole.

1.4 Risk assessment checklist

Use these checklists as part of your on-site risk assessment and include any additional considerations that may pertain to your specific application.

TABLE 1. RISK ASSESSMENT CHECKLIST BEFORE SET-UP

Before Set-up	
<input type="checkbox"/>	I took note of all the warning labels on the machine.
<input type="checkbox"/>	I removed or mitigated all identified risks (such as tripping, cutting, crushing, entanglement, shearing, or falling objects).
<input type="checkbox"/>	I considered the need for personnel safety guarding and installed any necessary guards.
<input type="checkbox"/>	I read the Machine Assembly instructions and took inventory of all the items required but not supplied.
<input type="checkbox"/>	I created a lift plan, including identifying the proper rigging, for each of the setup lifts required during the setup of the support structure and machine.
<input type="checkbox"/>	I located the fall paths involved in lifting and rigging operations. I have taken precautions to keep workers away from the identified fall path.
<input type="checkbox"/>	I considered how this machine operates and the best placement for the controls, cabling, and the operator.
<input type="checkbox"/>	I evaluated and mitigated any other potential risks specific to my work area.

TABLE 2. RISK ASSESSMENT CHECKLIST AFTER SET-UP

After Set-up	
<input type="checkbox"/>	I checked that the machine is safely and the potential fall path is clear. If the machine is elevated, I checked that the machine is safeguarded against falling.
<input type="checkbox"/>	I identified all possible pinch points, such as those caused by rotating parts, and informed the affected personnel.
<input type="checkbox"/>	I planned for containment of any chips or swarf produced by the machine.
<input type="checkbox"/>	I followed the Maintenance Intervals with the recommended lubricants.
<input type="checkbox"/>	I checked that all affected personnel have the recommended personal protective equipment, as well as any equipment required by the site or other regulations.
<input type="checkbox"/>	I checked that all affected personnel understand the danger zone and are clear of it.
<input type="checkbox"/>	I evaluated and mitigated any other potential risks specific to my work area.

2 CE

Recommended air pressure:	90 psi (DO NOT EXCEED 120 psi)
Temperature maximum:	25.7°C (Electric)

2.1 Audible Noise Levels

Electric Drive Option:

- Declared Sound Power Level is 80 dBA
- Declared Operator Sound Pressure Level is 79 dBA
- Declared Bystander Sound Pressure Level is 74 dBA









P/N 59037

2.2 Warning labels

The following warning labels should be on your machine. If any are defaced or missing, contact CLIMAX immediately for replacements.

TABLE 3 – DESCRIPTION OF LABELS

	<p>P/N 29154 CLIMAX serial number, year and model number plate.</p>		
	<p>P/N 29152 Label mass tag Weight = Approx. 100Kg</p>		
	<p>P/N 590440 Label safety warning circle read the manual</p>		<p>P/N78741 Label safety warning hand crush</p>

	<p>P/N 78742 Label safety warning entanglement of hand, or rotating shaft warning</p>		<p>P/N 78748 Label safety warning eye protection</p>
	<p>P/N 78824 Label safety warning do not expose to water</p>		<p>P/N 80510 label safety warning cutting of fingers, or rotating blade</p>
	<p>P/N 78593 Label safety warning electrical shock or electrocution</p>		<p>P/N 81008 label safety warning eye and ear protection required</p>
	<p>P/N 80207 lable safety warning entanglement rotating shaft</p>		

2.3 Machine Lock-Out



Air shutoff in the operating position (UP)

To lockout the machine, Push down on the lockout and insert locks into the openings at the bottom of the air shutoff on the air intake side of the pneumatic conditioning unit.



Recommended air pressure: 90 psi (**DO NOT EXCEED 120 psi**)

3 INTRODUCTION

3.1 About this manual

This manual describes how to use your Model PL2000 Portable Lathe.

CAUTION

To avoid severe personal injury, read and understand all instructions and warnings before operating this machine.

3.2 About the PL2000

The PL2000 Portable Lathe mounts to the end of the shaft. It is electrically or pneumatically powered. The compact design makes it an ideal on-site maintenance tool. The machine turns shafts 1.5" to 5" (38.1 - 127 mm) and up to 9" (228.6 mm) diameter with optional spacer assembly. The Model PL2000 has a reach of 12.5" (317.5 mm).

The PL2000 Portable Lathe machine consists of:

- Main Body Assembly
- Turning Bar Assembly
- Electric Motor Assembly (electric model only)
- Electric Planetary Housing Assembly (electric model only)
- Air Motor Assembly (air model only)
- Pneumatic Planetary Housing Assembly (air model only)
- Pneumatic Conditioning Unit (air model only)
- Tool Kit including Operating Manual

Exploded-view drawings and parts lists are included with this manual.

NOTICE

The PL2000 Portable Lathe machine must be rotating counter-clockwise (as viewed from the back of the motor) while machining. Do not rotate the PL2000 clockwise.

3.3 Electric lathe

The electric PL2000 Portable Lathe has a 9 amp electric motor. The motor may be either 120 volt or 230 volt, and it provides 780 no-load rpm and 510 load rpm. Check the serial number plate on the motor to find the voltage. The motor operates on 50 or 60 cycles AC current. A control pendant adjusts the motor speed.

The control pendant runs the motor at 0-70% of the maximum rpm.

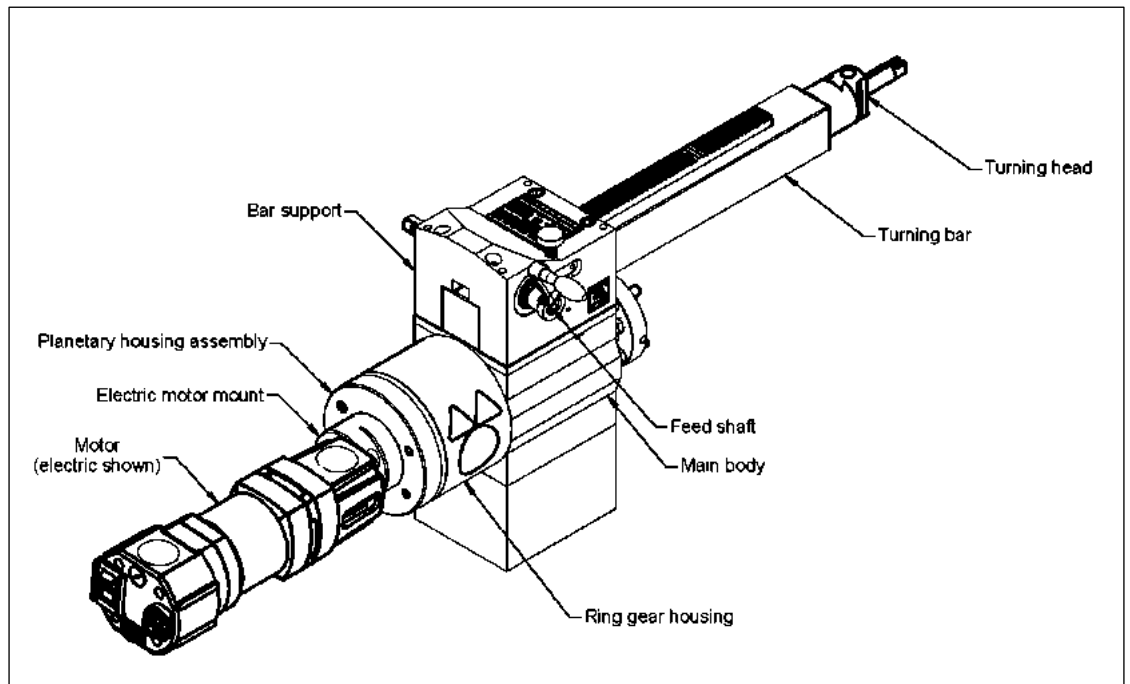

FIGURE 1 – ELECTRIC PORTABLE LATHE

CAUTION

The ON/OFF and reverse switches on the motor have been disabled for this machine; the motor is controlled from the control pendant. Any attempt to re-wire these cables might result in damage to the machine or the operator.

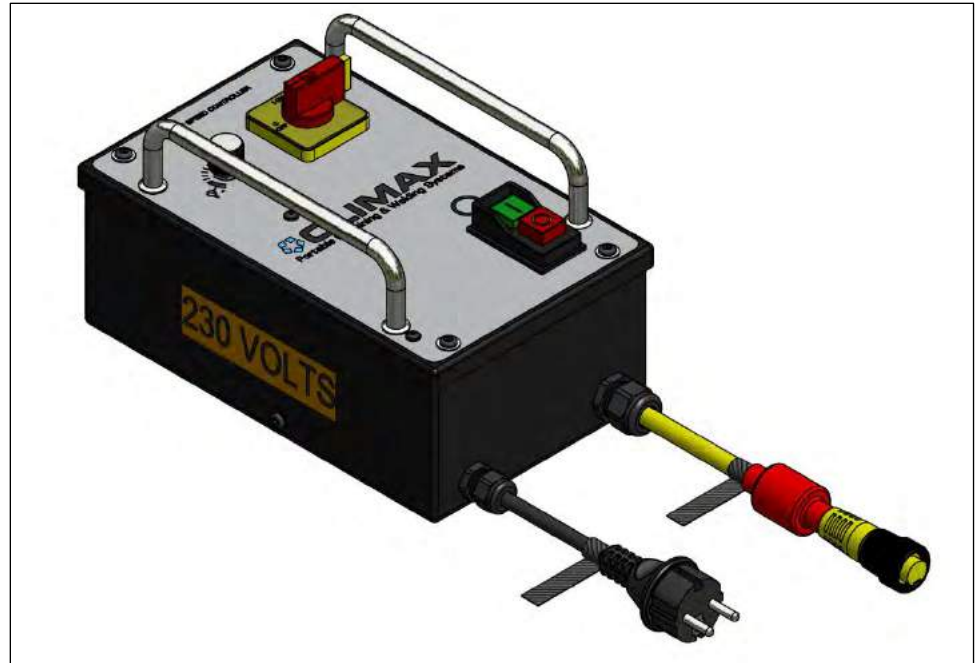

FIGURE 2 – CONTROLLER 10 AMP 230V 50/60 HZ P/N 79218

The control pendant for this machine is shown in Figure 2.

3.4 Pneumatic lathe

The pneumatic PL2000 Portable Lathe has a 1.22 HP (0.91 kW) air motor. Use the needle valve to adjust the motor speed.

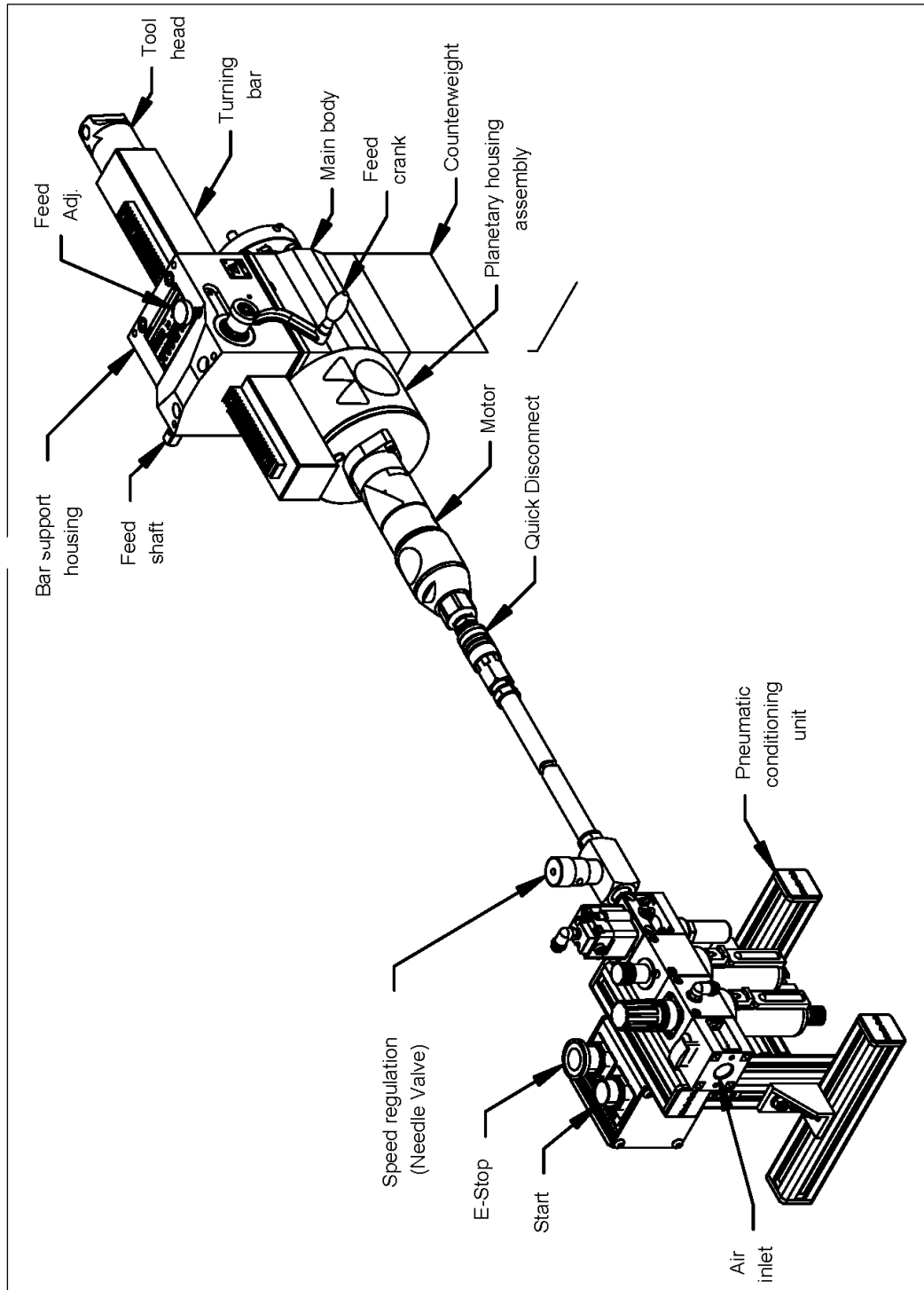

FIGURE 3 – PNEUMATIC PORTABLE LATHE (YOUR CONDITIONING UNIT MAY VARY FROM THE ILLUSTRATION).

CAUTION

Recommended operating pressure is 90 psi (620 kPa). DO NOT EXCEED 120 PSI (827 KPA)!

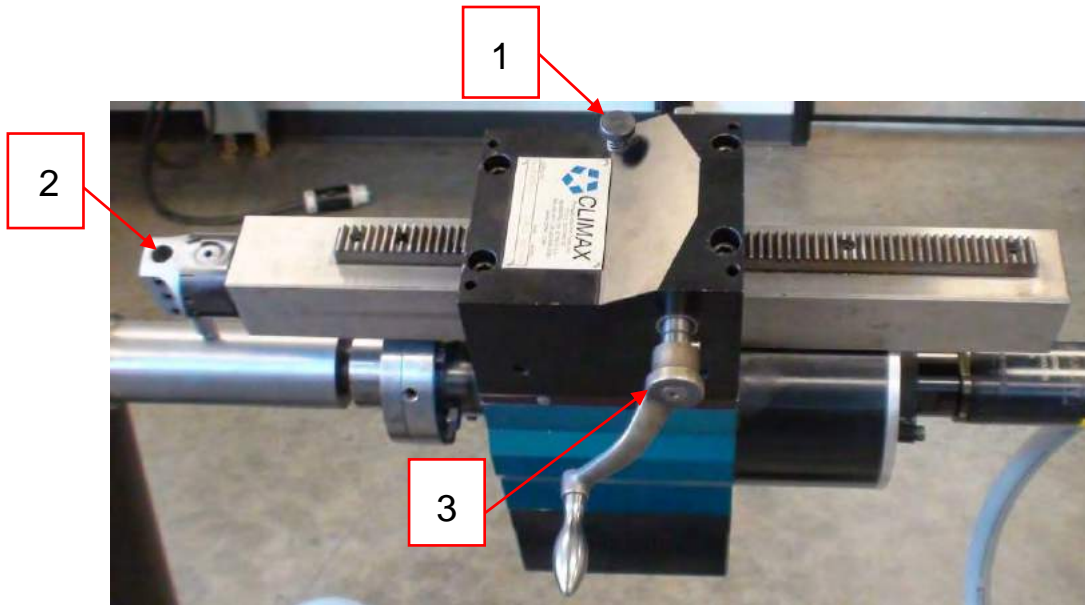

FIGURE 4 – (1) FEED RATE KNOB: CONTINUOUSLY VARIABLE FROM 0–0.025" (0–0.635 MM) PER REVOLUTION. (2) CRITERION STYLE TOOL HEAD: (3) FEED ENGAGEMENT SHAFT: USE WITH THE HAND CRANK FOR MANUAL POSITIONING.

4 SETUP

4.1 Receipt and Inspection

Your CLIMAX product was inspected and tested prior to shipment, and packaged for normal shipment conditions. CLIMAX does not guarantee the condition of your machine upon delivery. When you receive your CLIMAX product, perform the following receipt checks.

1. Inspect the shipping container(s) for damage.
2. Check the contents of the shipping container(s) against the included invoice to ensure that all components have been shipped.
3. Inspect all components for damage.

Contact CLIMAX immediately to report damaged or missing components.

CAUTION

To avoid bodily injury from moving machinery, turn off and disconnect all power cords before setting up the machine.

4.2 Preparing the mounting flange

The mounting flange of the PL2000 is 3.75" (95.25 mm) outside diameter and has four .40" (87.3 mm) diameter clearance holes for 3/8-24 mounting bolts. These holes are evenly spaced on a 3.03" (76.96 mm) diameter bolt circle. Between each of the clearance holes is a 3/8-24 tapped hole to accept jacking screws for leveling the machine.

1. Clean the end of the shaft and the face of the mounting flange.

NOTICE

Dirt, burrs, and grease on either the end of the work piece or the face of the flange will keep the flange from mounting properly.

2. Remove the motor, counterweights, turning bar, bar support and spacer assembly.
3. Loosely attach the machine flange to the end of the shaft.
4. Attach the turning bar, bar support, counterweights, and spacer assembly. Tighten the four bolts holding the bar support to the main body to 100 in/lbs.

4.3 Centering the machine

1. Crank the turning bar in until the tool head is as close as possible to the main body of the machine.
2. Attach a dial indicator to the tool head. Indicate as close to the center of the turning arm as possible.
3. Manually rotate the machine around the shaft. Using a soft mallet, tap the machine mounting flange until it is centered.
4. Snug the flange mounting screws.
5. Crank the turning bar out until the tool head and dial indicator are as far as possible from the machine.
6. Manually rotate the machine around the shaft. Adjust the three 3/8-24 jacking screws to align the machine.
7. Repeat steps #3 through #6 until the machine is centered.
8. Tighten all mounting screws.

WARNING

To avoid serious personal injury, keep clear of the hoist and the machine during setup.

4.4 Motor mounting

NOTICE

The PL2000 Portable Lathe machine must be rotating counter-clockwise (as viewed from the back of the motor) while machining. Do not rotate the PL2000 clockwise.

4.4.1 Electric motor mounting

1. Insert the planetary housing assembly into the internal ring gear of the main body. Tighten the five 1/4-20 socket head cap screws to 150 in-lbs (17 Nm).
2. Mount the electric motor mount onto the planetary housing. Tighten the five mounting screws to 150 in-lb (17 Nm).
3. Insert the electric motor assembly into the planetary gear housing. The electric motor assembly may need to be rotated slightly so that the gears mesh. Tighten the motor mount screws to 300 in-lb (34 Nm).

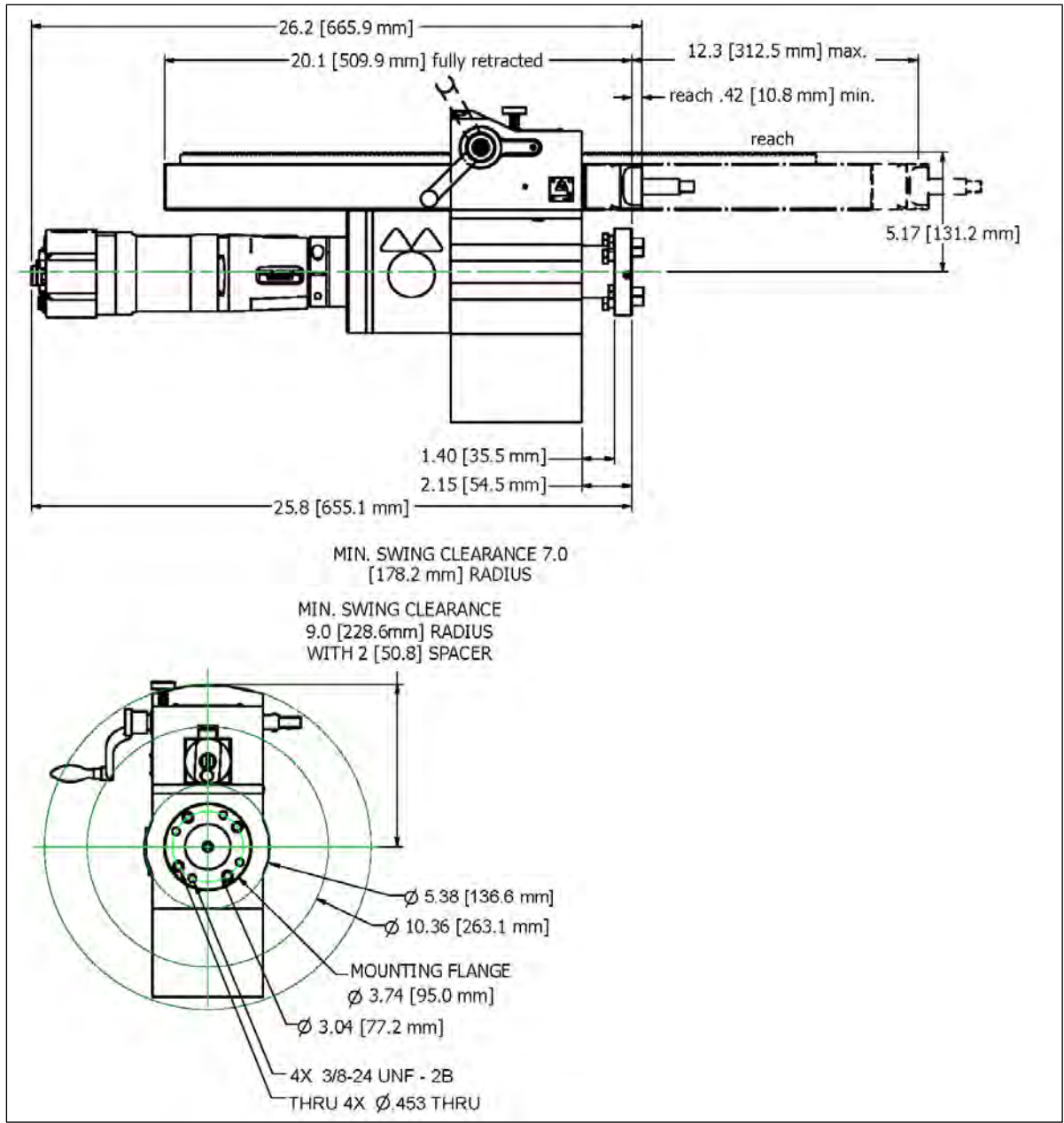

FIGURE 5 – ELECTRIC PORTABLE LATHE CLEARANCE DIMENSIONS (INCHES/MM)

4.4.2 Air motor mounting

CAUTION

To avoid serious personal injury from moving machinery, turn off and lock out the motor before connecting the air supply. Ensure that the needle valve is extended far enough from the machine for safe adjustment while in motion.

1. Insert the planetary housing assembly into the internal ring gear. Tighten the five mounting screws to 150 in-lb (17 Nm).
2. Mount the air motor assembly to the planetary housing. Tighten the two mounting screws to 150 in-lb (17 Nm).

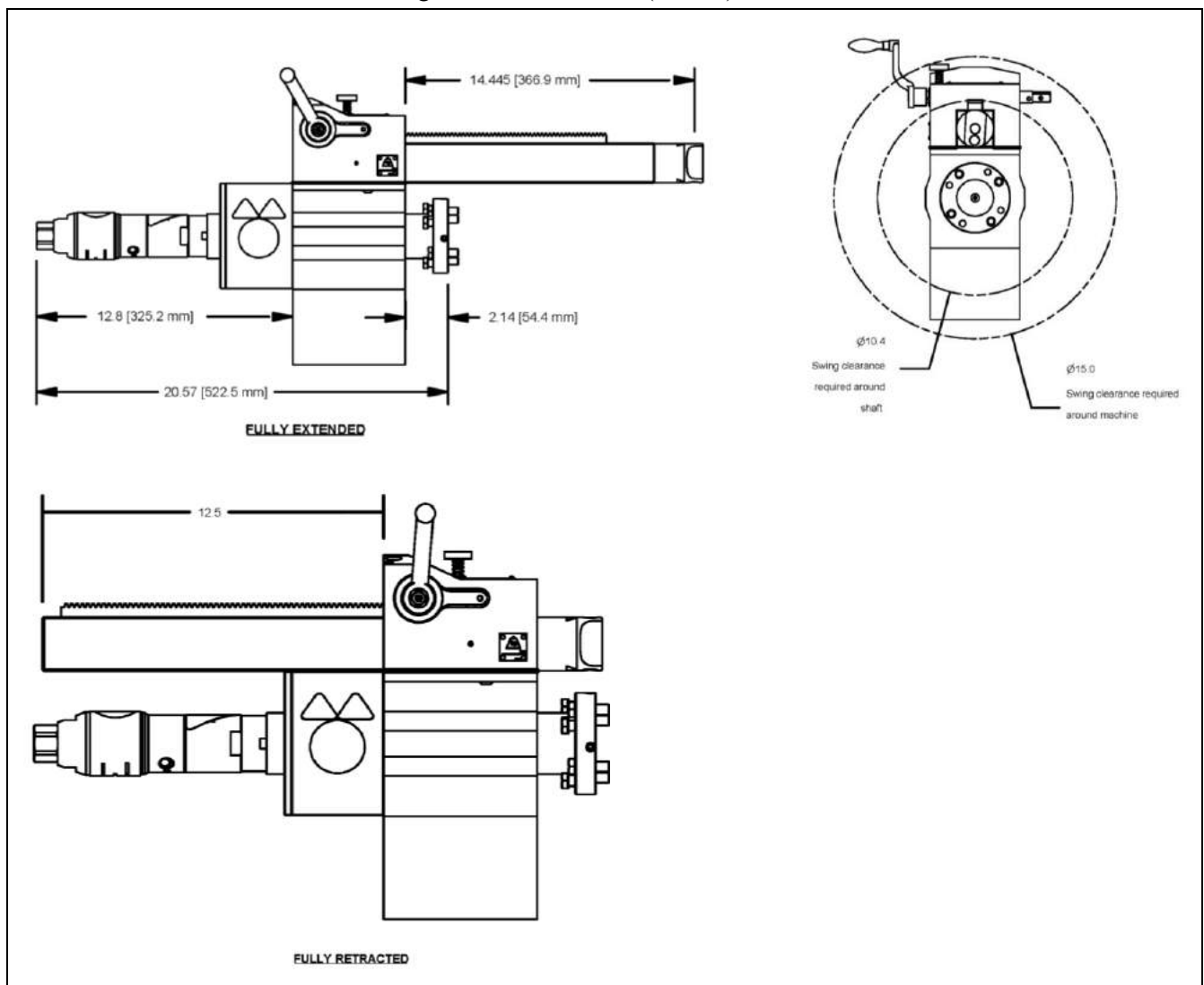

FIGURE 6 – PNEUMATIC PORTABLE LATHE CLEARANCE DIMENSIONS (INCHES/MM)

CAUTION

To avoid serious personal injury from moving machinery, turn off the motor BEFORE plugging it in.

3. Turn off the motor.
4. Turn the variable speed controller counterclockwise all the way.
5. Plug the machine into a properly grounded outlet.

CAUTION

To avoid injury by shock or explosion, do not operate electric motors in damp or explosive conditions.

4.5 Air power connection

CAUTION

To prevent serious injury from moving machinery during setup or adjustment, use quick disconnect fittings between the air supply line and the needle valve. Close and lock out all air valves before connecting the air supply line to the motor.

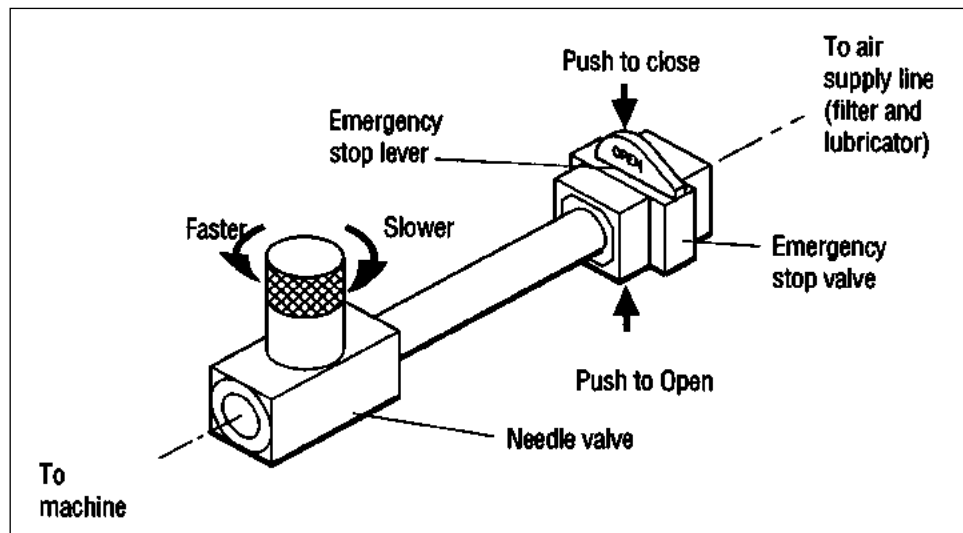

FIGURE 7- LOCKOUT VALVE

The PL2000 Portable Lathe has a 1.22 hp (.91 kW) air motor. Adjust motor speed using the needle valve.

The air filter and lubricator (pneumatic conditioning unit) supplied with the machine must be used or the warranty is void. The lubricator should be set to deliver oil at a rate of 2-4 drops per minute.

CAUTION

To prevent damage to the machine, use the filter and lubricator provided.

The PL2000 Portable Lathe is equipped with a needle valve/lockout valve assembly.

NOTICE

Air line connections should be made with nonrestrictive air fittings of not less than 3/8" dia.

4.5.1 To start the machine:

1. Turn the needle valve clockwise all the way. No colored bands will be visible when the valve is completely closed.
2. Push the emergency stop lever down until the word CLOSED and the lockout can be seen from the bottom of the valve. Be sure the lever is pushed all the way.

CAUTION

To prevent serious injury from moving machinery, secure the machine to the work piece before connecting the air supply.

3. Push the emergency stop lever up until the word OPEN can be seen from the top of the valve. Be sure the lever is pushed all the way.
4. Slowly turn the needle valve counterclockwise until the machine is turning at the desired speed. The more colored bands you see, the faster the machine speed.

CAUTION

In case of emergency push the emergency stop lever closed.

4.5.2 To stop the machine:

1. Turn the needle valve clockwise all the way. No colored bands will be visible when the valve is completely closed.
2. Push the emergency stop lever down until the word CLOSED and the lockout can be seen from the bottom of the valve. Be sure the lever is pushed all the way. Lock out the machine with a padlock.

4.6 Tool bit preparation

1. Grind a 1/2" round tool bit. See Figure 8 for grinding information.

NOTICE

High-speed tool bits may perform better than carbide tools. Carbide bits tend to ride up or skid on the surface.

CAUTION

Correct tool bit geometry is critical to the performance of the machine. Never use tool bits without checking their geometry.

2. Check the geometry of the HSS tool bit against the tool geometry diagrams, next page. Tool bits with low clearance angles may reduce chatter and cut better. Exact tooling geometry also depends on the type of material being cut.
3. Center the tool head's moveable part with the stationary part.
4. Move the tool holder so that it is over the work piece.
5. Slide the tool bit into the tool head until the tool bit touches the work piece. Tighten the three set screws to secure the tool.

CAUTION

To prevent serious bodily injury from moving machinery, turn off and disconnect the power before inserting or adjusting the tool bit.

6. Reposition the tool by using the manual hand crank so the tool is off the end of the work piece.
7. Adjust the tool downward (clockwise) to the desired depth of cut. The dial is in .001" (.025 mm) graduations on the diameter. Therefore, turning the dial .020" (.508 mm) down will remove .020" (.508 mm) off the diameter or be a .010" (.254 mm) depth of cut.

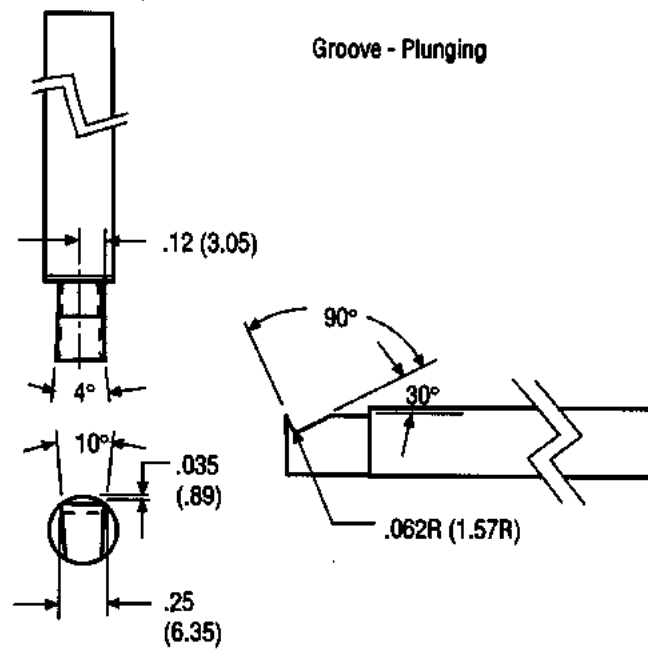
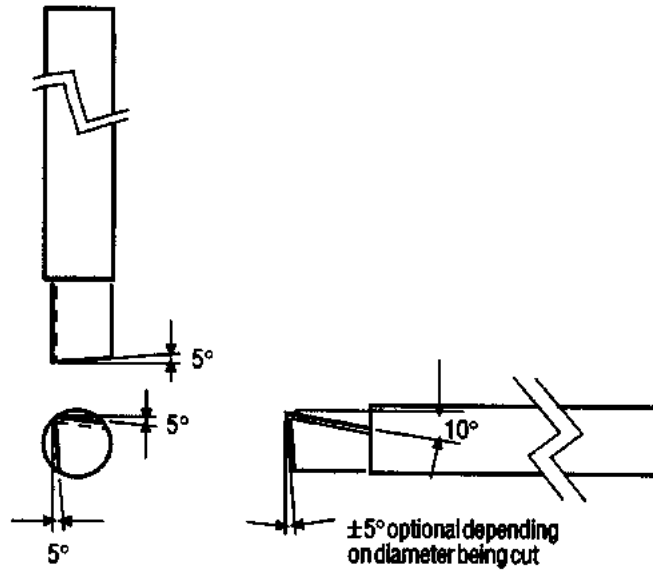

FIGURE 8 – TOOL BIT GEOMETRY - INCH (MM)

4.7 Manual Axial feed

1. Using the crank handle, move the tool bit to the end of the work piece.
2. Engage the feed by pushing in the end of the pinion shaft until the pin engages with the slot.
3. Adjust the feed rate by turning the adjustment knob. Clockwise slows the feed rate and counterclockwise increases the feed rate.

4.7.1 Setting rotational speed

CAUTION

To prevent serious bodily injury from moving machinery, turn off and disconnect the power before adjusting machine feeds.

Rotational speed rate is variable up to 95 rpm.

NOTICE

The PL2000 Portable Lathe machine must be rotating counterclockwise (as viewed from the back of the motor) while machining. Do not rotate the PL2000 clockwise.

4.7.2 Electric speed adjustment

To adjust the speed on electric machines, slowly turn the speed control.

4.7.3 Pneumatic speed adjustment

To adjust the speed on pneumatic machines, slowly turn the needle valve.

5 OPERATION

5.1 Pre-start checks

CAUTION

To prevent serious bodily injury from moving machinery, turn off and disconnect the machine before performing pre-start checks.

5.1.1 General pre-start checks

1. Be sure tool bits are sharp.
2. Check that all moving parts move freely.

5.1.2 Electric lathe pre-start checks

1. Inspect electrical parts for damage.
2. Be sure power is OFF before plugging in unit.
3. Plug the machine into a grounded outlet.

5.1.3 Pneumatic lathe pre-start checks

1. Fill the air lubricator with air oil. Use an air oil that has antioxidants and rust inhibitors such as Marvel Air Tool Oil. Set the lubricator to deliver oil at a rate of 2-4 drops per minute.
2. Drain the air filter.
3. Push the emergency stop lever down until the word **CLOSED** and the lockout can be seen from the bottom of the valve. Be sure the lever is pushed all the way.
4. Turn the needle valve clockwise all the way. You will not be able to see any of the colored bands when the valve is completely closed.
5. Check that the in-line air pressure is 90 psi (620 kPa). Be sure air lines are not restricted or damaged.

5.2 Operation

CAUTION

To protect yourself from flying chips and excessive noise, wear eye and ear protection while operating the machine.

NOTICE

The PL2000 Portable Lathe machine must be rotating counter-clockwise (as viewed from the back of the motor) while machining. Do not rotate the PL2000 clockwise.

1. Be sure the power is off.
1. Using the crank handle, retract the turning bar until the tool head is as close to the machine as possible.
2. Crank the turning bar out until the cutter is just over the shaft.

CAUTION

Because the feed moves the cutter away from the mounting flange, start the cut with the bar fully retracted.

3. Turn the depth adjustment knob clockwise until the cutter just touches the shaft.
4. Retract the turning bar until the cutter just clears the end of the shaft.
5. Turn the depth adjusting knob to set the tool bit to the desired depth. Turning the knob clockwise adjusts the tool downward. The dial is in .001" (.025 mm) graduations on the diameter.
6. Set the axial feed lever to desired feed rate. Clockwise slows the feed rate down and counterclockwise speeds the feed rate up.
7. Engage the feed by pushing the end of the pinion shaft in until the pin in the shaft engages with the detente slot.
8. Remove the hand crank from the machine.
9. Start the machine. To adjust the speed on electric machines, slowly turn the speed control. To adjust the speed on pneumatic machines, slowly open or close the needle valve.
10. After the desired length of shaft has been turned, gradually turn the motor speed down until the machine stops rotating.
11. Using the hand crank, retract the cutter.
12. Repeat Steps #1 through #12 until the shaft is turned to the desired size or finish.

TIP:

For finer finish cuts, set the tool bit for a shallower cut and run the machine at a slower feed rate.

13. Shaft polishing can also improve the finish and minimize taper. For more information, see “Shaft Polishing” on page 27.

5.3 Taper adjustment

The PL2000 Portable Lathe is equipped with a feature for fine adjustment of the turning bar, and improve a taper condition in the work piece.

1. Perform a test cut on your work piece. Measure both ends of the test cut with a micrometer to check for taper.
2. Adjust taper with the four jacking screws accessible from the top of the turning bar support, and four mounting screws that hold the turning bar support to the main body of the machine.
3. Mount a dial indicator to the bar, with the stylus of the indicator against the test cut. Tighten either the two front or the two rear jacking screws, and slightly loosen the corresponding mounting bolts, to allow for bar movement. Observe the dial indicator movement for desired movement of the bar (indicator movement should be about half of test cut taper).

CAUTION

Do not over-tighten the turning bar support screws beyond 10 ft-lbs, or binding of the turning bar may occur, resulting in damage to the machine. For finer adjustment, sections of the shaft can be polished to more closely match diameters of other sections of the bar.

5.4 Single bolt mounting adapter

The single bolt mounting adapter secures the PL2000 on shafts under 3.75" (95.25 mm) diameter.

Drill and tap a 5/8-11 hole in the end of the work piece. Be sure that thread is at least 1" (25.4 mm) deep. Mount the adapter, then attach the machine mounting flange to the adapter as described in Section "Setup".

5.5 Shaft polishing

With the abrasive belt holder (included with the machine) and an abrasive belt (user supplied), the PL2000 Portable Lathe can polish shafts.

CAUTION

To avoid serious personal injury from moving machinery, turn off and disconnect the power before setting up the abrasive belt.

5.6 Setting the abrasive belt holder

1. Attach an abrasive belt holder to the end of the turning bar.
2. Wrap an abrasive belt around the shaft and through the slot into the holder.
3. Using a wrench, tighten the abrasive belt holder until the belt is snug against the work piece. Tighten the set screw.

5.7 Spot polishing

1. Position the belt as desired on the shaft.
2. Start the machine.
3. Run the machine until the shaft has the desired finish. Spot polishing can also be used to minimize taper along the length of a shaft.

5.8 Polishing the entire shaft

1. Position the belt on the end of the shaft.
2. Engage the feed system.
3. Start the machine. The machine will automatically feed the belt along the shaft.

6 DISASSEMBLY

CAUTION

To prevent serious bodily injury from moving machinery, turn off and lock out and disconnect the power supply before disconnecting the machine.

To disassemble the PL2000 Portable Lathe:

1. Turn off and disconnect the power supply.
2. Turn the depth adjustment knob counterclockwise to retract the cutter.
3. Remove the tool.
4. Remove the motor from the planetary housing.
5. Remove the bar support and turning bar.
6. Remove the counterweight.
7. Secure the machine with a hoist.
8. Remove the machine from the shaft.

7 MAINTENANCE

7.1 Recommended lubricants

TABLE 4 – RECCOMENDED LUBRICANTS

LUBRICANT	BRAND	WHERE USED
Gear grease	Polytac EP #2	Planetary housing gears
Light oil	JET LUBE 500	Unpainted surfaces
Cutting oil	UNOCAL KOOLKUT	Tool bits, work piece
Lubricating oil	Unax AW 32	Lubricator oil cup (pneumatic model)

CAUTION

To prevent machine damage use recommended type lubricants.

7.2 Main body

Under normal conditions the main body is maintenance-free.

7.3 Mounting flange

Clean the flange before use. Spray unpainted surfaces with WD-40.

7.4 Turning bar assembly

Lightly oil the turning bar every time you use the lathe.

7.5 Electric motor

CAUTION

To avoid injury by shock or explosion do not operate electric motors in damp or explosive conditions.

Repack the gear case every 6 months or 500 hours with one ounce of gear grease. Remove the gear case, being careful not to dislodge the armature.

NOTICE

Do not disassemble the gears.

Periodically inspect the brushes:

- Unscrew the brush retainer caps on the motor housing.
- Pull out the retainer springs and brushes.

Replace brushes when they have worn down to 1/4" in depth (6 mm). Always replace the brushes in sets.

7.6 Air motor and pneumatic conditioning unit

1. Route incoming air through the lubricator and air filter.
2. Use nonrestrictive air lines and fittings. Check periodically that air pressure is 90 psi (620 kPa).
3. Adjust air motor torque by turning the needle valve.

NOTICE

Do not adjust the motor speed by changing the in-line air pressure from 90 psi (620 kPa).

4. Fill the air lubricator oil cup with oil before using the machine. Use high-quality oil with rust inhibitors and emulsifiers such as Marvel Air Tool Oil. The lubricator should oil the air at a rate of 2-4 drops per minute.
5. Drain the air filter before and after using the machine.

CAUTION

To avoid machine damage, never operate the machine without the air filter and lubricator

7.7 Planetary housing

1. When necessary, repack the gears with gear grease.
2. Spray exposed housing surfaces with JET LUBE 500.

For further information on recommended lubricants see Section 7.1.

8 STORAGE

Proper storage of the PL2000 Portable Lathe will prevent undue deterioration or damage.

- Before storing the machine, clean it with solvent to remove grease, metal chips, and moisture.
- Drain the air filter on pneumatic machines.
- Spray the machine with a moisture-protective material (JET LUBE 500 for short storage, LPS3e for long storage) to prevent rusting.
- Store the machine in the crate provided.
- Place desiccant bags or vapor wrap around the machine to absorb moisture.

Call CLIMAX to replace a storage container (P/N 16783).

APPENDIX A SPECIFICATIONS



SPECIFICATIONS

	US	Metric
Machine Performance Ranges		
Turning Reach	12.5 inches	317.5 mm
Shaft dia. maximum		
without optional spacer/counterweight assembly	5.0 inches	127.0 mm
with the optional spacer/counterweight assembly	9.0 inches	228.6 mm
Shaft dia. minimum		
without optional spacer/counterweight assembly	1.5 inches	38.1 mm
Shaft dia. minimum	5.0 inches	127.0 mm
with the optional spacer/counterweight assembly		
Feed rate, automatic (infinitely variable)	0 - 0.035 inches/rev.	0 - 0.89 mm/rev
Cutter modified	1/2 inch (12.7 mm) HSS round lathe tool bit	
Power Options		
Power, electric		
120V, 60 Hz or 230V, 50Hz	0.75 Hp	0.55 kW
Torque: 43 ft-lbs (58 N·m). Bar speed: 14 - 115 rpm max.		
Motor Speed: 780 rpm no load, 510 rpm full load.		
Power, pneumatic	1.22 Hp	0.91 kW
(non-reversing, Hp rated at 200 rpm). Torque: 95 ft-lbs (127.6 N·m) at 55 rpm bar speed. Bar speed: 0 - 95 rpm max.		
Motor speed: 375 rpm no load, 200 rpm full load. Infinitely variable speed control with needle valve.		
Air flow required: 90 psi @ 30 ft ³ /min (620 kPa @ 0.85 m ³ /min).		
Measures		
Overall length, electric		
bar fully retracted	26.0 inches	666.4 mm
bar fully extended	39.0 inches	990.6 mm
Overall length, pneumatic		
bar fully retracted	32.0 inches	812.8 mm
bar fully extended	44.5 inches	1130.3 mm
Overall height	13.75 inches	349.3 mm
without optional spacer/counterweight assembly		
with optional spacer/counterweight assembly	17.75 inches	450.9 mm
Operating weight, electric motor		
without spacers or counterweights	99 lbs	44.9 kg
with spacers and counterweights	116 lbs	52.6 kg
Operating weight, pneumatic motor		
without spacers or counterweights	94 lbs	42.6 kg
with spacers and counterweights	111 lbs	52.3 kg
Shipping weight	190 lbs	86.2 kg
Shipping dimensions L x W x H	26 x 19 x 15 inches	660.4 x 482.6 x 381.0 mm

APPENDIX B EXPLODED VIEWS AND PARTS

NOTICE

The following diagrams and parts lists are for reference purposes only. The machine Limited Warranty is void if the machine has been tampered with by anyone who has not been authorized in writing by CLIMAX to perform service on the machine.

8.2 List of exploded views and parts

P/N 59037	4
FIGURE 2 – CONTROLLER 10 AMP 230V 50/60 HZ P/N 79218	9
FIGURE 5 – ELECTRIC PORTABLE LATHE CLEARANCE DIMENSIONS (INCHES/MM)	14
FIGURE 6 – PNEUMATIC PORTABLE LATHE CLEARANCE DIMENSIONS (INCHES/MM)	15
FIGURE 7- LOCKOUT VALVE	16
FIGURE 8 – TOOL BIT GEOMETRY - INCH (MM).....	19
TABLE 4 – RECCOMENDED LUBRICANTS.....	26
FIGURE 9 – P/N 31594 BAR TURNING SUPPORT FEED ASSY	31
FIGURE 10 – P/N 31594 BAR TURNING SUPPORT FEED ASSY PARTS LIST	32
FIGURE 11 – P/N 30333 ASSY PNEUMATIC POWER MODULE PL2000	33
FIGURE 12 – P/N 78264 PNEUMATIC CONDITIONING UNIT 1/2 IN LOW PRES.....	34
FIGURE 13 – P/N78264 PNEUMATIC CONDITIONING UNIT 1/2 IN LOW PRES.PARTS LIST	35
FIGURE 14 – P/N78264 PNEUMATIC CONDITIONING UNIT 1/2 IN LOW PRES. DROPOUT SCHEMATIC.....	36
FIGURE 15 – P/N 29998 ASSY PNEUMATIC PL2000.....	37
FIGURE 16 – P/N 31586 ASSY MAIN BODY 2 ND PL2000.....	38
FIGURE 17 – P/N 31590 SPACER ASSY 5-9 IN DIAMETER	39
FIGURE 18 -- CONTROLLER SCHEMATIC 10 AMP 230 V 50/60 Hz CE 79218	40
FIGURE 19 – P/N 79218 CONTROLLER 10 AMP 230 V 50/60 Hz CE	41
FIGURE 20 – P/N 79218 CONTROLLER 10 AMP 230 V 50/60 Hz CE MULTIPLE MODEL	42
FIGURE 21 – P/N 79218 CONTROLLER 10 AMP 230 V 50/60 Hz CE MULTIPLE MODEL PARTS LIST	43
FIGURE 22 – P/N 30572 SINGLE BOLT ADAPTER ASSY	44
FIGURE 23 – P/N 30407 INDICATOR ASSY PL2000	45
FIGURE 24 – P/N 31585 ASSY MAIN BODY & BAR ASSY 2 ND PL2000	46
FIGURE 25 – P/N 30309 DRIVE ROTATIONAL PL2000 ELECTRIC 120V AND P/N 30816 DRIVE ROTATIONAL PL2000 230V	47
FIGURE 26 – P/N 31584 MODEL PL2000 PORTABLE LATE AIR 2 ND	48

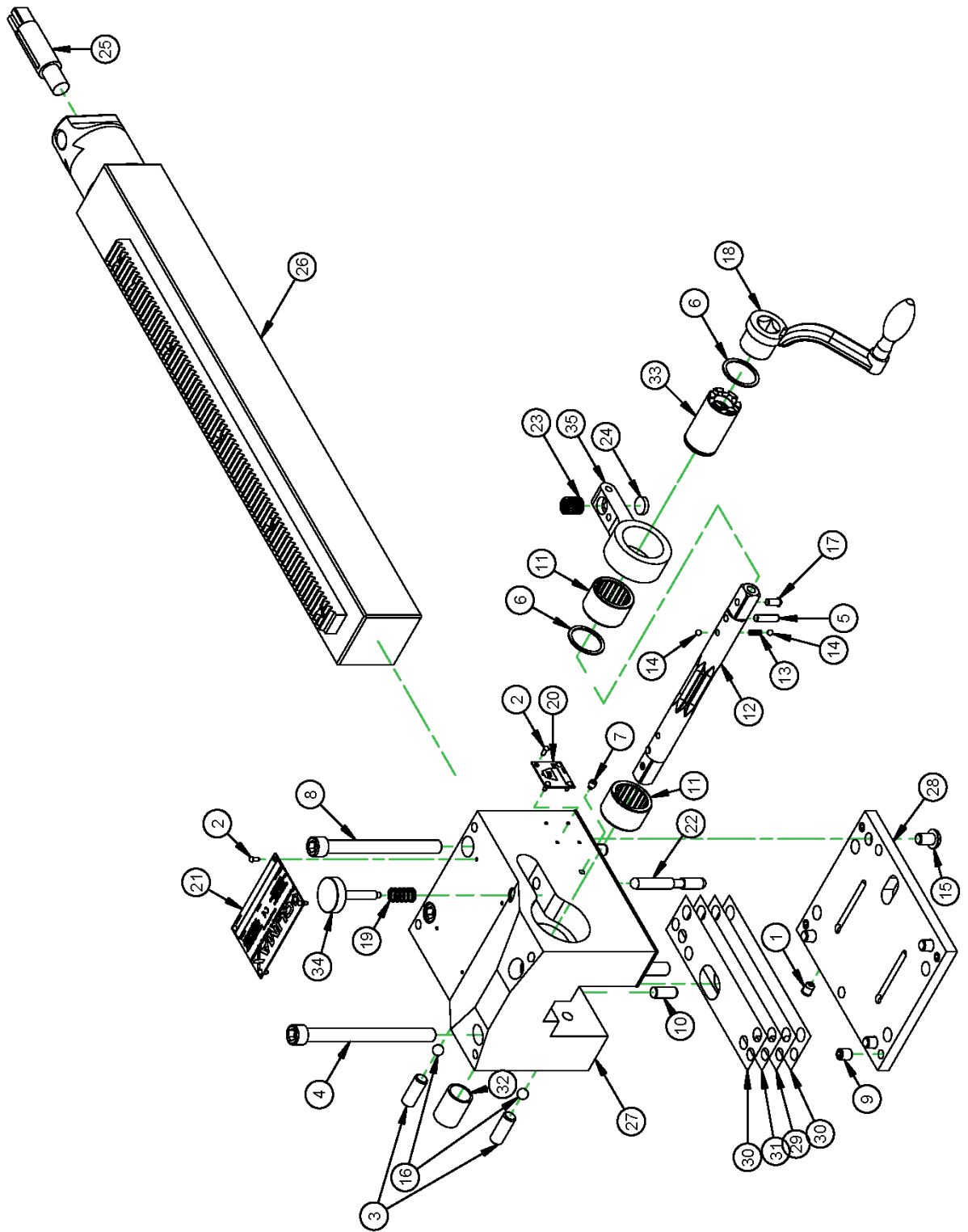
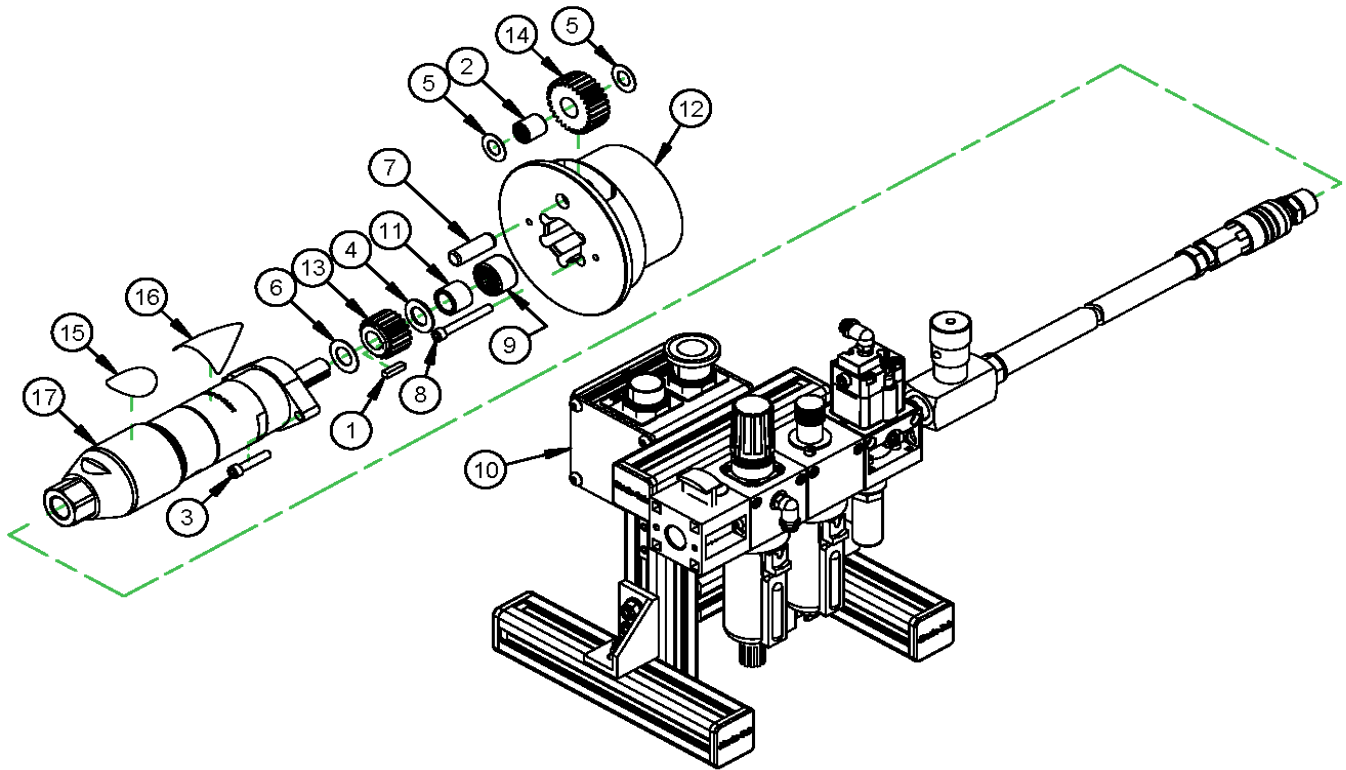

FIGURE 9 – P/N 31594 BAR TURNING SUPPORT FEED ASSY

PARTS LIST			
ITEM	QTY	P/N:	DESCRIPTION
1	2	10139	OILER BALL VALVE DRIVE IN
2	8	10588	SCREW DRIVE #2 x 1/4 HOLE SIZE .089
3	2	10946	SCREW 3/8-16 X 1 SSSFP
4	2	11097	SCREW 3/8-16 X 4-1/2 SHCS
5	2	11763	PIN DOWEL 3/16 x 3/4
6	2	14241	RING SNAP 1 OD SPIRAL HEAVY DUTY
7	1	15395	SCREW 10-32 X 1/4 SSSHDP
8	2	15743	SCREW 3/8-16 X 4 SHCS
9	4	15744	SCREW 5/16-18 X 3/8 SSSFP
10	2	16540	PIN DOWEL 5/16 DIA X 3/4
11	2	19307	BRG ROLLER CLUTCH .984 ID 1.26 OD X .787
12	1	19344	SHAFT PINION AXIAL FEED BB3000 PL2000
13	1	19561	SPRING COMP .148 OD X .023 WIRE X .50 LONG STAINLESS
14	2	19562	BALL STEEL 5/32 DIA
15	4	21769	5/16-18 X 1/2 BHSCS
16	2	26506	BALL NYLON 5/16 DIA
17	2	26828	PLUNGER BALL PUSHFIT
18	1	26850	HANDLE CRANK MODIFIED
19	1	26922	SPRING .36 OD X .032 X 2.25 LONG
20	1	29152	PLATE MASS CE
21	1	29154	PLATE SERIAL YEAR MODEL CE 2.0 X 3.0
22	1	29991	ROD PUSH UPPER
23	1	30039	SPRING COMP .48 OD X .051 WIRE X .50 LONG
24	1	30056	PLUG FEED ARM
25	1	30389	HOLDER ABRASIVE BELT PL2000
26	1	31196	BAR TURNING ASSY PL2000
27	1	31556	SUPPORT BAR 2ND
28	1	31557	PLATE BAR RETENTION PL2000
29	A/R	31649	SHIM BAR SUPPORT .001
30	A/R	31650	SHIM BAR SUPPORT .002
31	A/R	31695	SHIM BAR SUPPORT .0005
32	1	41261	BRG RACE MODIFIED .6256 ID X .875 OD X 1
33	1	43219	BUSHING FEED DIRECTION BB FACING HEAD
34	1	43275	KNOB KNURLED 1.0 OD X 1/4-20 X 1-1/2
35	1	43276	LEVER FEED PL2000

FIGURE 10 – P/N 31594 BAR TURNING SUPPORT FEED ASSY PARTS LIST



PARTS LIST

ITEM	QTY	P/N:	DESCRIPTION
1	1	10217	KEY 3/16 SQ X .75 SQ BOTH ENDS
2	1	10434	BRG NEEDLE 1/2 ID X 11/16 OD X .750 OPEN
3	2	10671	SCREW 1/4-20 X 1-1/4 SHCS
4	1	11165	WASHER THRUST .625 ID X 1.125 OD X .060
5	2	11736	WASHER THRUST .500 ID X .937 OD X .030
6	1	11823	WASHER THRUST .625 ID X 1.125 OD X .030
7	1	11832	PIN DOWEL 1/2 DIA X 1-1/2
8	5	12444	SCREW 1/4-20 X 2 SHCS
9	1	15305	BRG NEEDLE 7/8 ID X 1-1/8 OD X 3/4 OPEN
10	1	29998	ASSY PNEUMATIC PL2000
11	1	30308	BRG RACE .625 ID X .875 OD X .76
12	1	30316	HOUSING PLANETARY AIR
13	1	30334	GEAR SPUR MODIFIED
14	1	30335	GEAR IDLER AIR
15	1	59044	LABEL WARNING - CONSULT OPERATOR'S MANUAL 1.5 DIA
16	1	80207	LABEL WARNING - ENTANGLEMENT/ROTATING SHAFT GRAPHIC 1.95 TALL TRIANGLE YELLOW
17	1	80902	MOTOR AIR 177 RPM AT MAX PWR 382 RPM FS CW

FIGURE 11 – P/N 30333 ASSY PNEUMATIC POWER MODULE PL2000

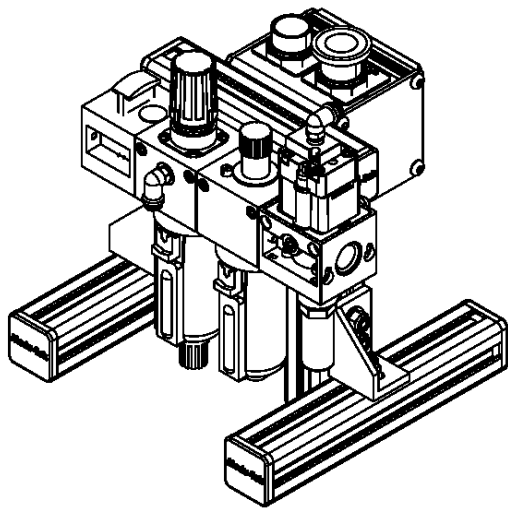

ASSEMBLED
SCALE 1 : 5

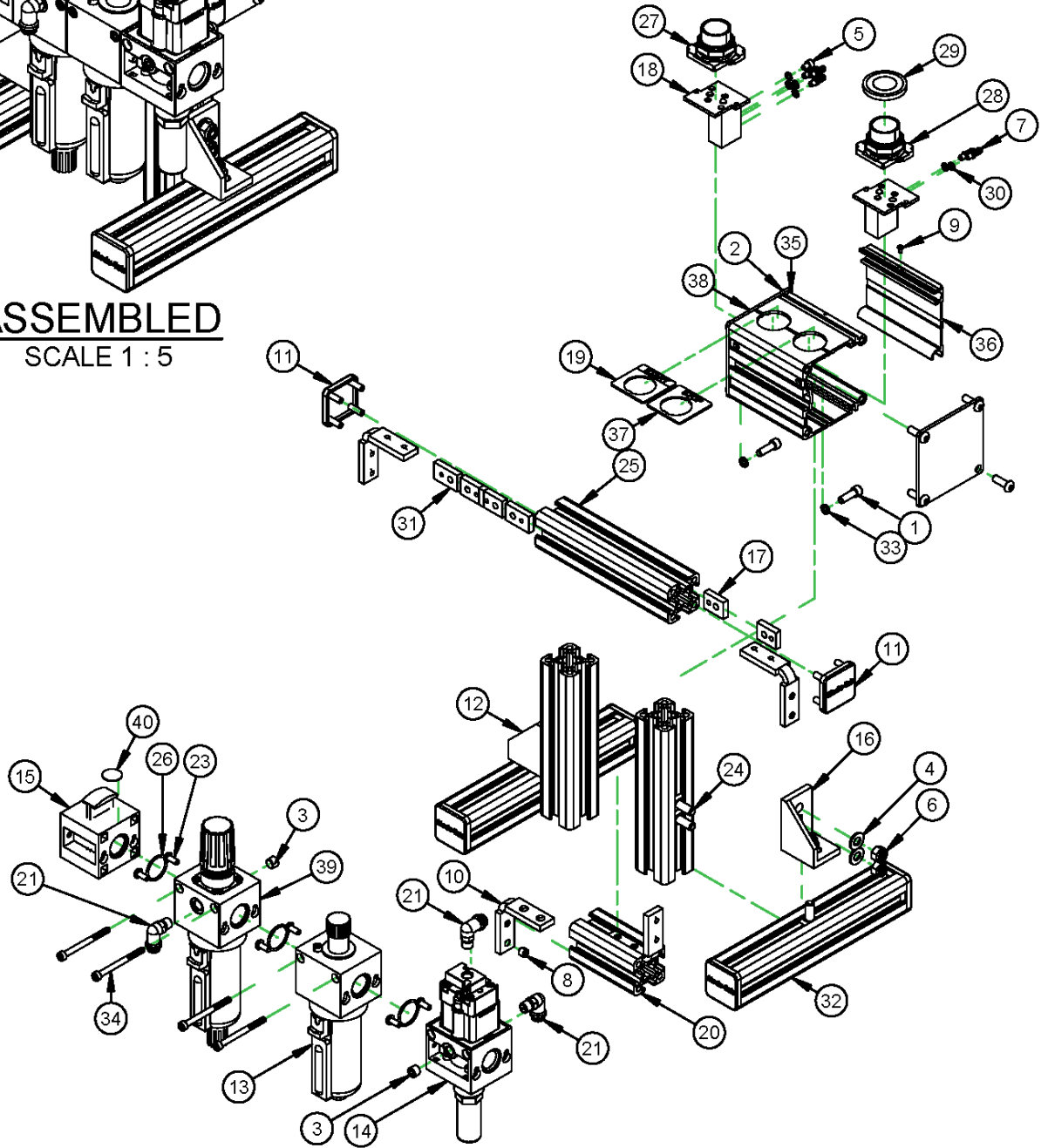

FIGURE 12 – P/N 78264 PNEUMATIC CONDITIONING UNIT 1/2 IN LOW PRES.

PARTS LIST			
ITEM	QTY	P/N:	DESCRIPTION
1	2	10160	SCREW 1/4-20 X 3/4 SHCS
2	8	11365	SCREW 1/4-20 X 3/4 BHSCS
3	2	12616	FTG PLUG 1/8 NPTM SOCKET
4	6	13489	WASHER 5/16 FLTW SAE
5	1	14726	SCREW 10-32 X 1/4 SHCS
6	6	19729	NUT 5/16-18 NYLON INSERT LOCKNUT
7	5	22235	FTG BARB #10-32 X 1/8 HOSE
8	16	27895	SCREW 5/16-18 X 5/16 SSSFP
9	1	35857	SCREW 4-40 X 1/4 FHSCS
10	4	46761	BRACKET 90DEG JOINER MODU-TEK
11	6	46764	ENDCAP 1 X 1 FOR 1.63SQ MODU-TEK EXTRUSION
12	1	46765	BRACKET 1X2 SLOT HALF WEB LEFT MODU-TEK
13	1	46768	LUBRICATOR AIR 1/2 NPTF 3.8oz BOWL W/SIGHT
14	1	46769	VALVE EXHAUST QUICK PILOT 1/2NPTF MUFFLER
15	1	46777	VALVE SHUT OFF VS22 SERIES
16	1	46783	BRACKET 1X2 SLOT HALF WEB RIGHT MODU-TEK
17	2	46784	NUT SQUARE 5/16-18 AND 1/4-20
18	2	46785	VALVE PUSHBUTTON 5 PORT PNEUMATIC
19	1	46797	LEGEND PLATE START 10250 SERIES
20	1	46802	1.63 X 1.63 X 3.375L MODU-TEK EXTRUSION
21	3	48648	FTG ELBOW 1/8 NPTM X 1/4 TUBE PRESTOLOK
22	60	48650	TUBING 1/4 OD POLYURETHANE (INCH) (NOT SHOWN)
23	6	53617	SCREW M5 X 0.8 X 12MM BHCS BLACK FINISH
24	6	59436	SCREW 5/16-18 X 3/4 T-BOLT
25	3	59437	1.63 X 1.63 X 7.00L MODU-TEK EXTRUSION
26	3	59442	O-RING 2mm X 23mm ID X 25mm OD
27	1	59458	PUSHBUTTON GREEN FLUSH
28	1	59459	PUSH BUTTON PUSH PULL MAINTAINED (M-M)
29	1	59462	PUSH BUTTON OPERATOR RED 1-5/8
30	6	59480	WASHER #10 FLTW PLASTIC .32 OD .025 THICK
31	4	59705	NUT PLATE M5 X .08 AND 5/16-32 .75 X 1.25 X .25
32	2	59739	EXTRUSION 1.63 X 1.63 X 8.75 MODU-TEK
33	2	59745	WASHER 1/4 LOCW .37 OD .07 THICK
34	4	59754	SCREW M5 X 0.8 X 40MM SHCS
35	1	59820	ENCLOSURE PNEUMATIC CONTROL VALVE 3.38 X 3.435 X 3.9
36	1	59821	COVER PNEUMATIC CONTROL VALVE ENCLOSURE 3.38 X 3.435 X 3.9
37	1	59825	LEGEND PLATE STOP 10250SERIES YELLOW BACKGROUND
38	2	68644	PLATE COVER EXTRUDED WIREWAY
39	1	78054	FILTER/REGULATOR PARTICULATE 1/2NPTF METAL BOWL GLASS
40	1	81132	LABEL WARNING - INSERT SAFETY LOCK

FIGURE 13 – P/N78264 PNEUMATIC CONDITIONING UNIT 1/2 IN LOW PRES.PARTS LIST

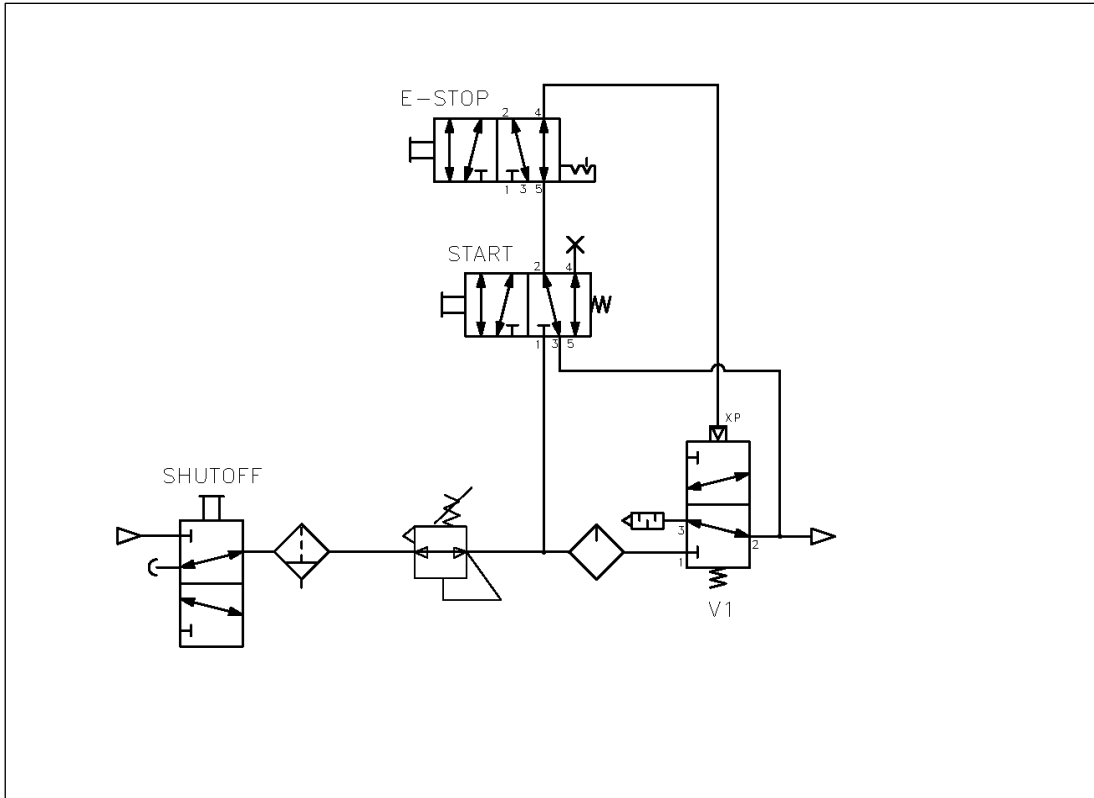
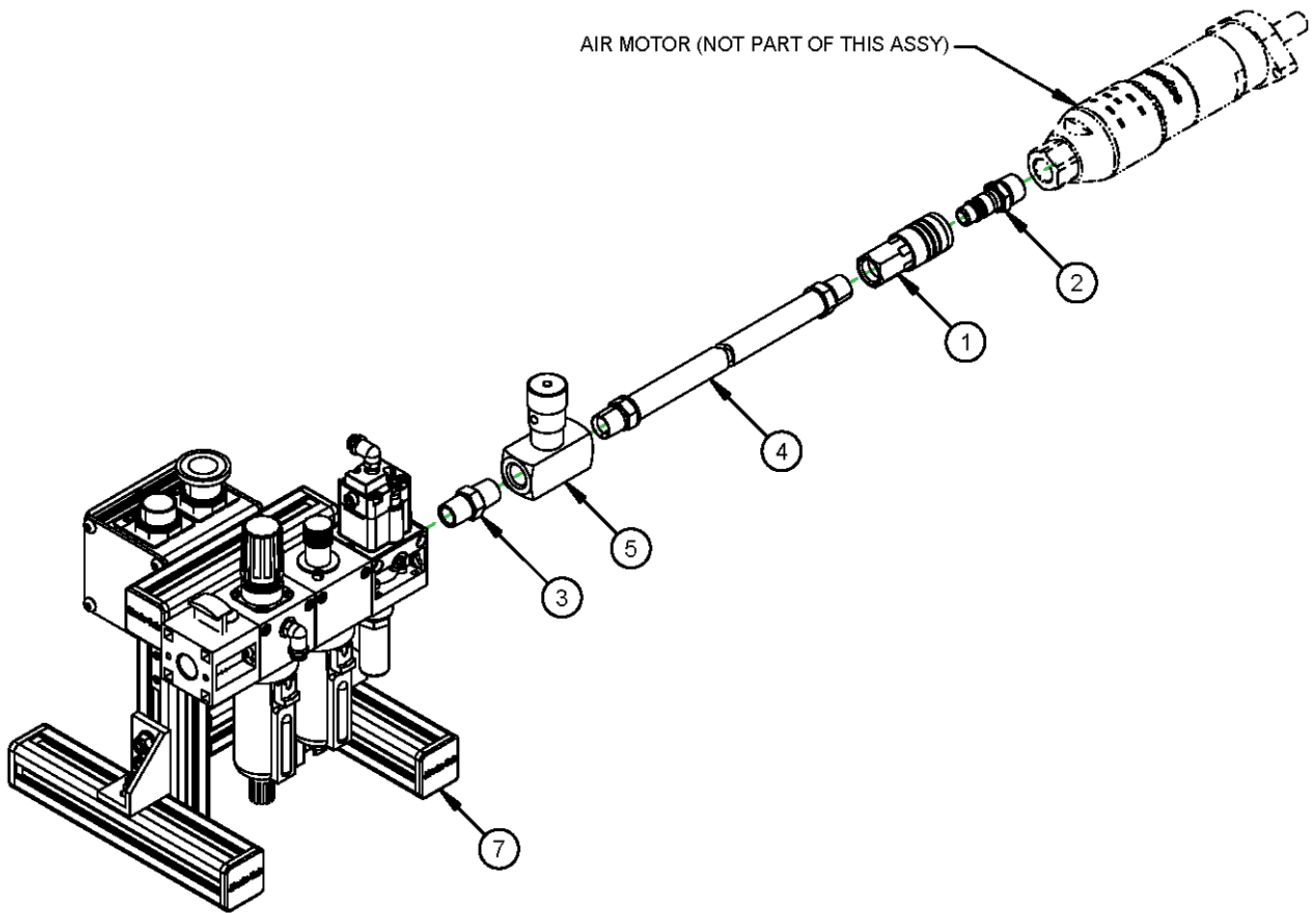
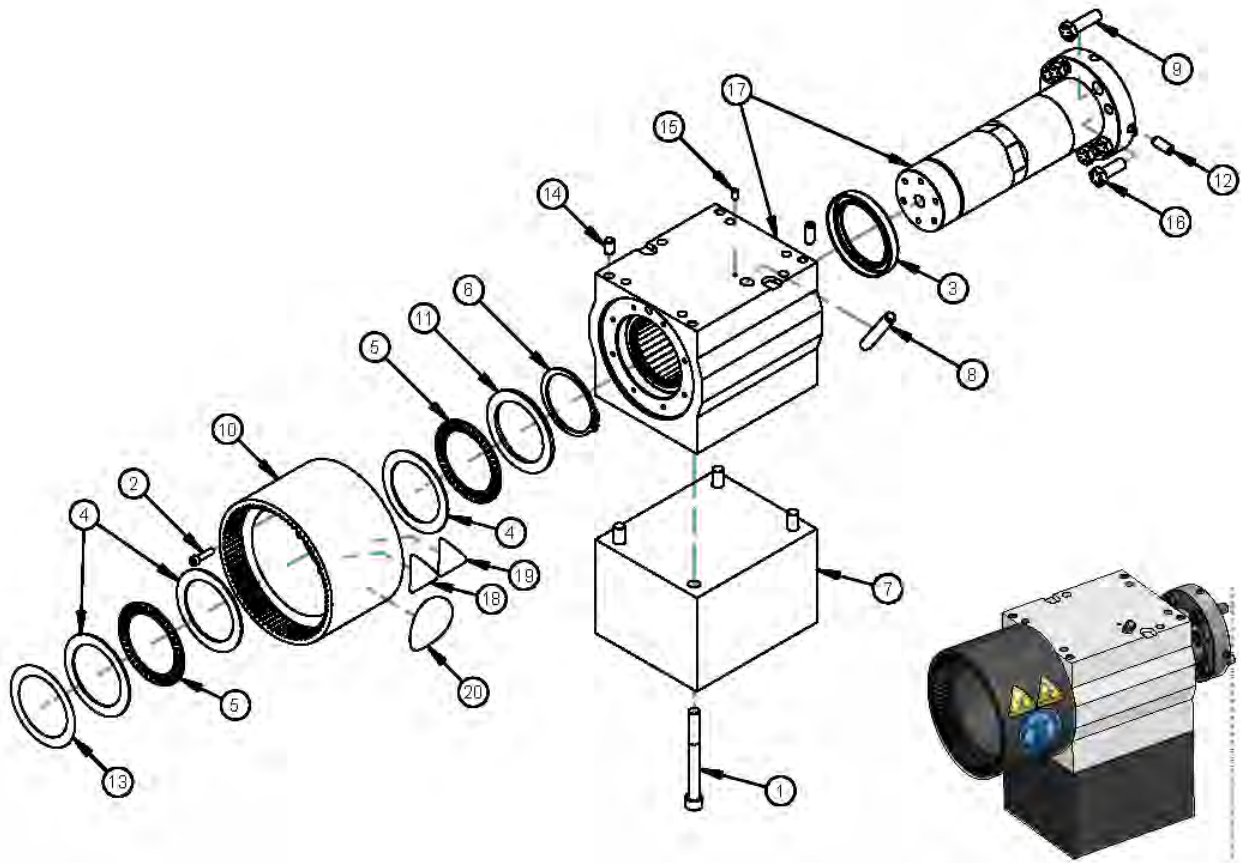

FIGURE 14 – P/N78264 PNEUMATIC CONDITIONING UNIT 1/2 IN LOW PRES. DROPOUT SCHEMATIC



PARTS LIST			
ITEM	QTY	P/N:	DESCRIPTION
1	1	13208	FTG QD COUPLER 1/2B 1/2 NPTF PNEUMATIC
2	1	13209	FTG QD NIPPLE 1/2B 1/2 NPTM PNEUMATIC
3	1	14704	FTG NIPPLE 1/2 NPTM X 1/2 NPTM
4	1	15915	HOSE ASSY 801 1/2 X 1/2 NPTMS X 1/2 NPTMS X 72
5	1	22229	VALVE NEEDLE 1/2 IN.
6	1	34866	(NOT SHOWN) OIL AIRTOOL COMPLETE
7	1	78264	PNEUMATIC CONDITIONING UNIT 1/2 IN LOW PRES. DROPOUT

FIGURE 15 – P/N 29998 ASSY PNEUMATIC PL2000



PARTS LIST			
ITEM	QTY	P/N:	DESCRIPTION
1	4	11064	SCREW 3/8-16 X 3-1/2 SHCS
2	8	12648	SCREW 10-24 X 3/4 SHCS
3	1	16107	SEAL 2.250 ID X 3.000 OD X .375
4	3	16114	WASHER THRUST 2.250 ID X 3.000 OD X .060
5	2	16115	BRG THRUST 2.250 ID X 3.000 OD X .0781
6	1	16136	RING SNAP 2-1/4 OD X .078 TH
7	1	30006	COUNTERWEIGHT 28 LB PL2000
8	1	30007	ROD PUSH LOWER
9	4	30037	SCREW 3/8-24 X 1-1/4 HHCS GRADE 8
10	1	30281	GEAR RING PL2000
11	1	30307	WASHER THRUST 2.250 ID X 3.000 OD X .125
12	4	30586	SCREW 8-32 X 1/4 SSSFP BRASS TIP
13	A/R	30839	SHIM 2-1/4 ID X 3 OD X .002
		30840	SHIM 2-1/4 ID X 3 OD X .003
		30841	SHIM 2-1/4 ID X 3 OD X .010
14	4	31592	PIN DOWEL 5/16 x 1/2
15	1	32012	SCREW 10-32 X 3/8 SSSCP
16	4	33761	SCREW 3/8-24 X 1 HHCS GRADE 8
17	1	52173	ASSY SPINDLE AND HOUSING PL2000
18	1	78741	LABEL WARNING CRUSH FOOT
19	1	78742	LABEL WARNING ENTANGLEMENT OF HAND/ROTATING SHAFT GRAPHIC 1.13 TALL TRIANGLE YELLOW
20	1	81008	LABEL WEAR HEARING AND EYE PROTECTION 2 INCH ROUND

FIGURE 16 – P/N 31586 ASSY MAIN BODY 2ND PL2000

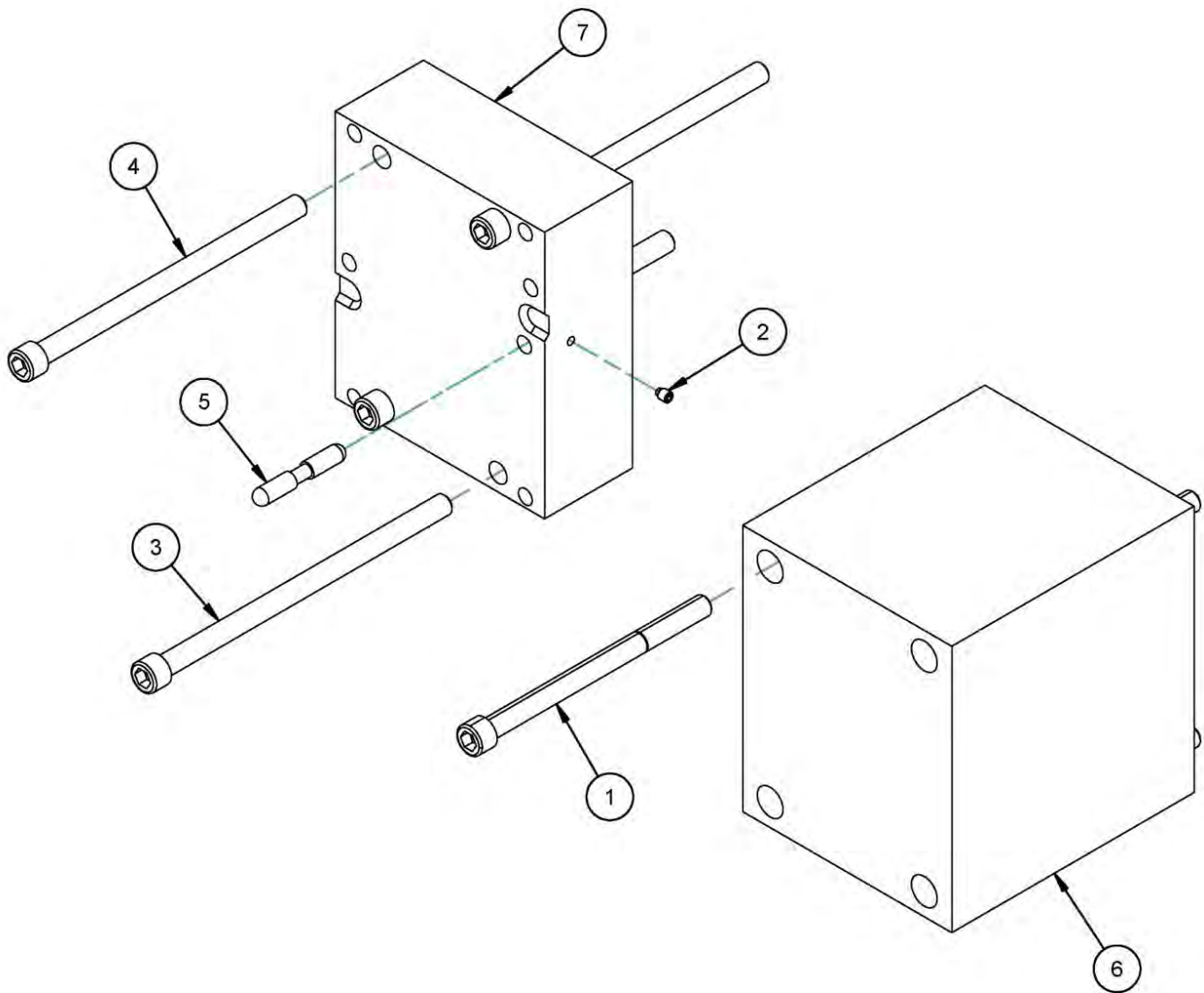

PARTS LIST			
ITEM	QTY	PART No.	DESCRIPTION
1	4	15213	SCREW 3/8-16 X 5 SHCS
2	1	15395	SCREW 10-32 X 1/4 SSSHDP
3	2	15541	SCREW 3/8-16 X 6-1/2 SHCS
4	2	15613	SCREW 3/8-16 X 6 SHCS
5	1	30055	ROD PUSH SPACER
6	1	30437	COUNTERWEIGHT 41 LB
7	1	31580	SPACER 2 IN 2ND

FIGURE 17 – P/N 31590 SPACER ASSY 5-9 IN DIAMETER

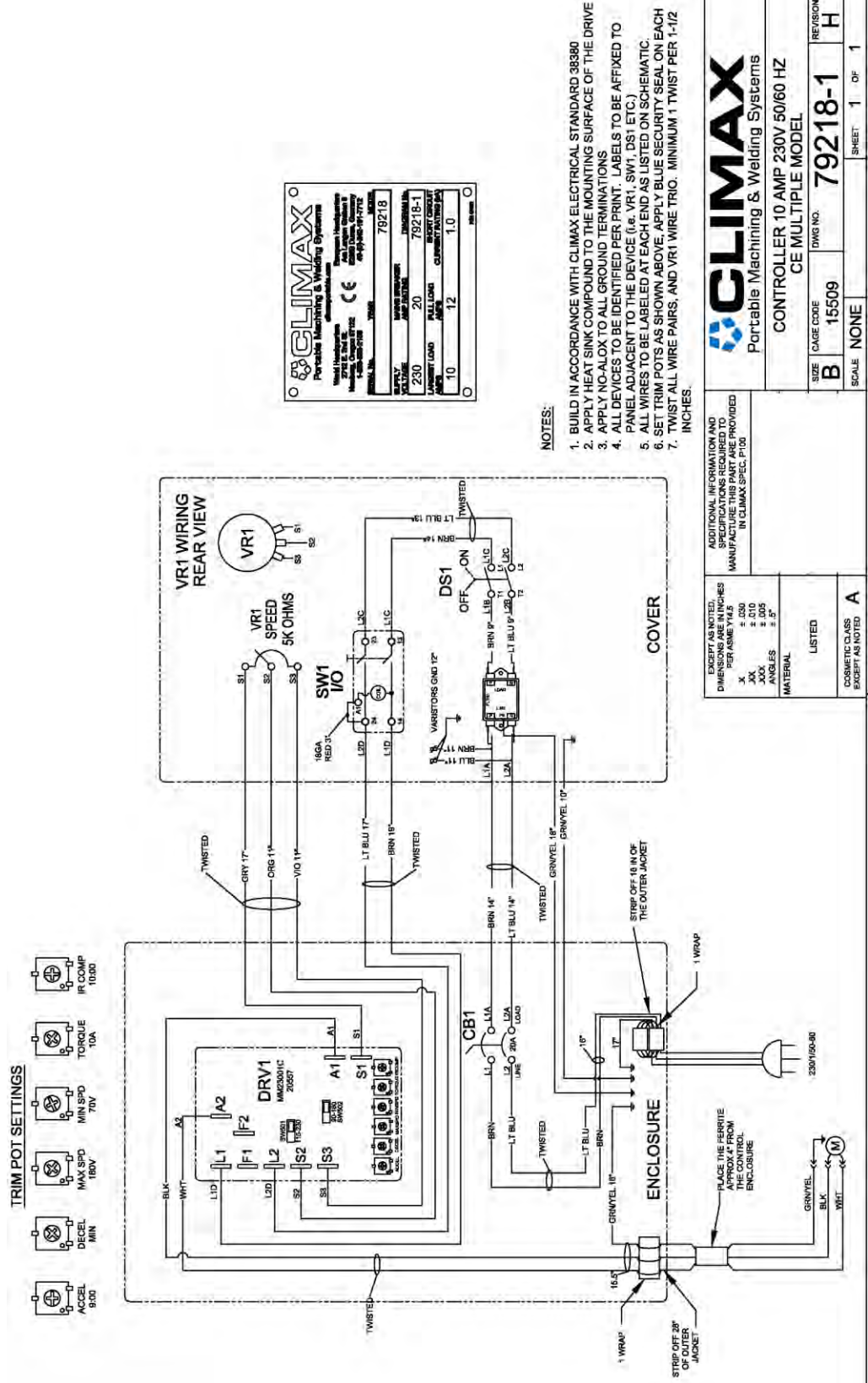

FIGURE 18 -- CONTROLLER SCHEMATIC 10 AMP 230 V 50/60 Hz CE 79218

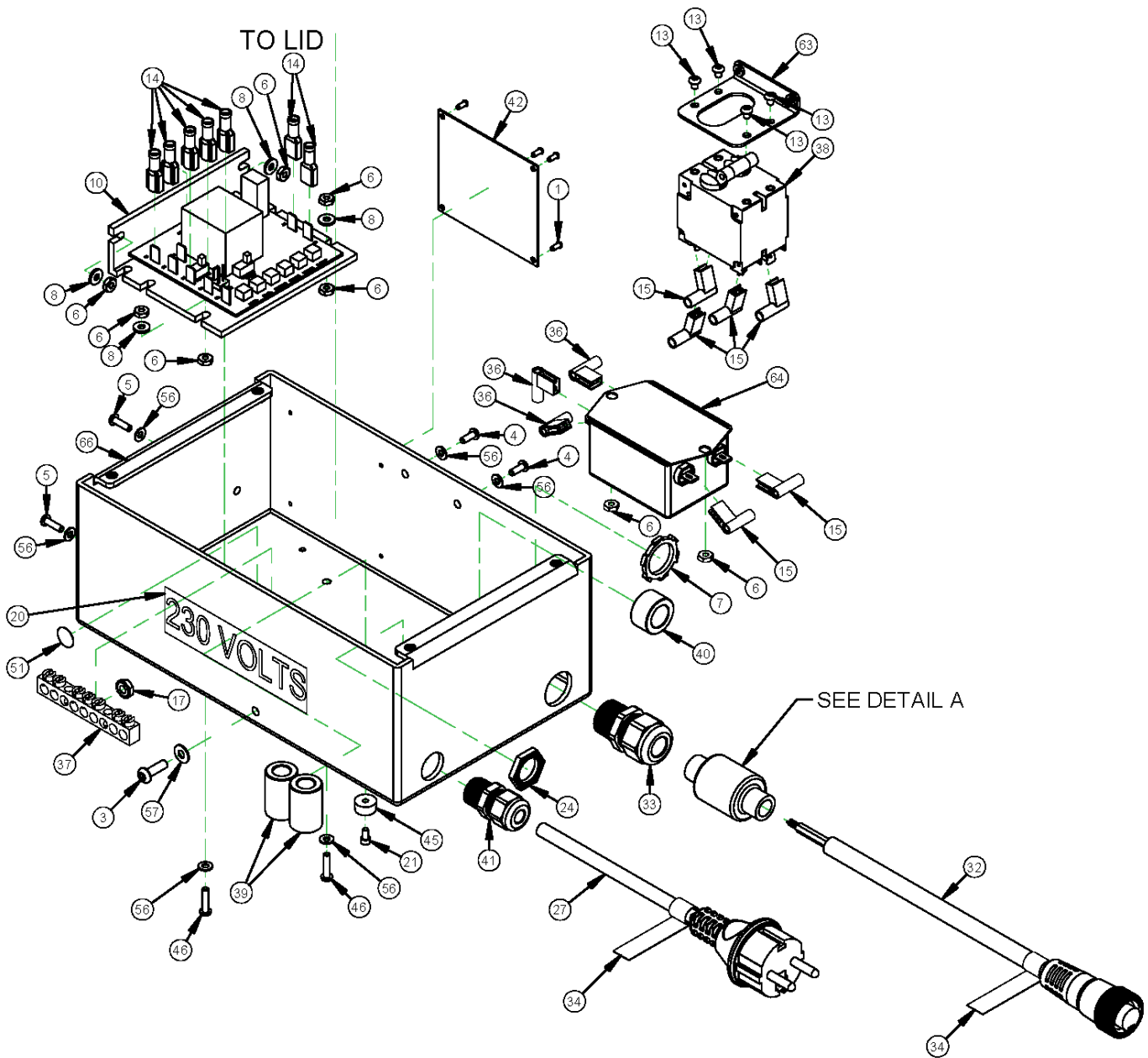
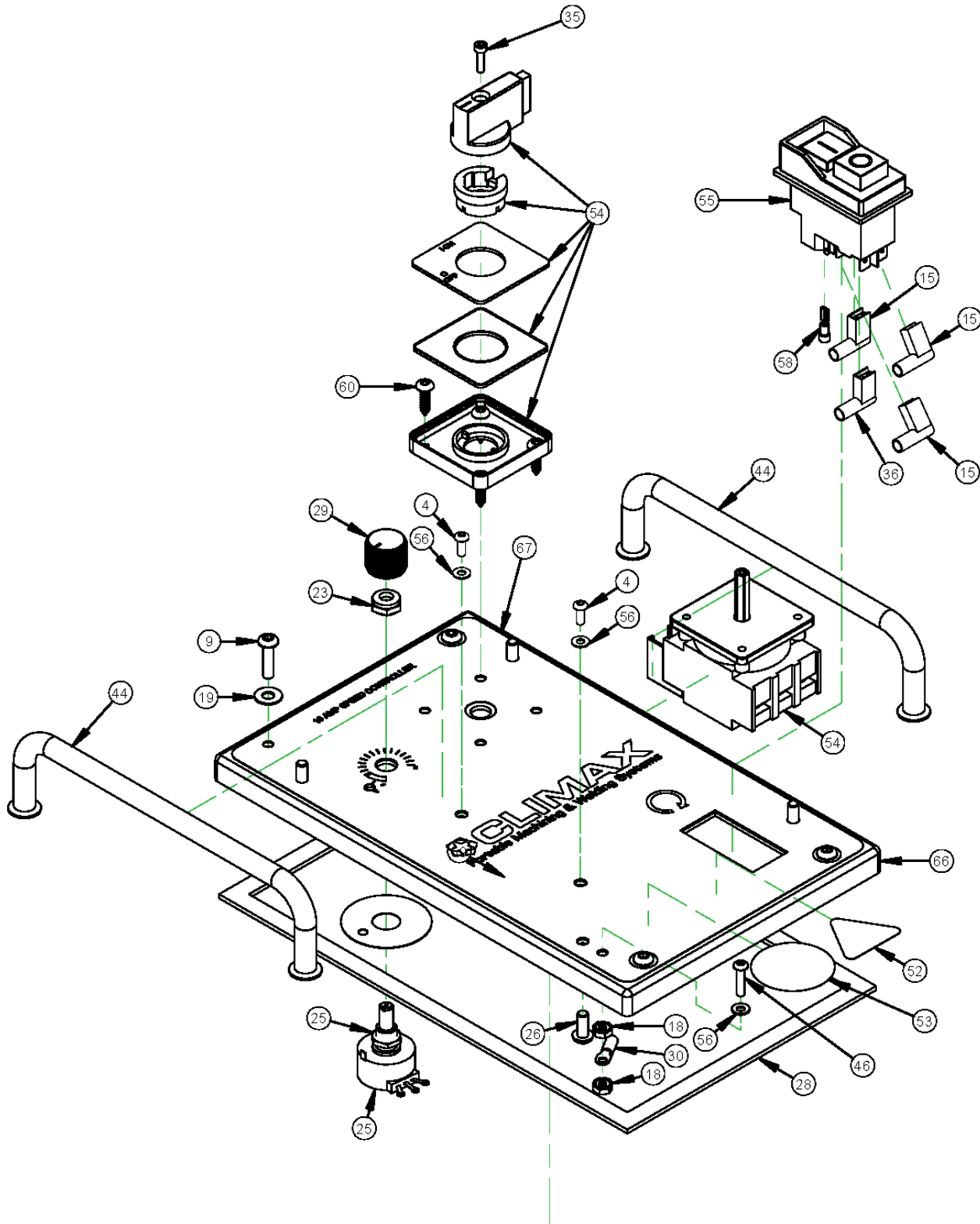

FIGURE 19 – P/N 79218 CONTROLLER 10 AMP 230 V 50/60 Hz CE



TO ENCLOSURE

FIGURE 20 – P/N 79218 CONTROLLER 10 AMP 230 V 50/60 HZ CE MULTIPLE MODEL

PARTS LIST				PARTS LIST			
ITEM	QTY	P/N:	DESCRIPTION	ITEM	QTY	P/N:	DESCRIPTION
1	4	10588	SCREW DRIVE #2 x 1/4 HOLE SIZE .089	37	1	38444	GROUND BUSS 7 POLE COPPER CE CERTIFIED
2	10	10673	(NOT SHOWN) WIRE TIE SMALL .09 X 3.5	38	1	42798	CIRCUIT BREAKER 20 AMP DOUBLE POLE
3	1	11674	SCREW #10-32 X 5/8 BHSCS	39	2	45158	FERRITE BEAD TUBULAR .398 ID X .735 OD X 1.125 LG
4	4	11677	SCREW 6-32 X 3/8 BHSCS	40	1	45159	FERRITE BEAD TUBULAR .545 ID X .88 OD X .50
5	2	11686	SCREW 6-32 X 1/2 BHSCS	41	1	46383	CORD GRIP .105- .312 DIA 3/8 NPT
6	8	11687	NUT 6-32 STDN ZINC PLATED	42	1	47981	NAMEPLATE ELECTRICAL CONTROL PANELS CE
7	1	12574	CONDUIT NUT 1/2 NPT	43	1	48778	CHOKER FERRITE 1.02 OD X 0.505 ID X 1.125 125 OHM @25MHZ
8	4	12621	WASHER #6 FLTW SAE ZINC	44	2	52160	HANDLE 180MM X 43MM U-SHAPED CHROME
9	4	18902	SCREW 10-32 X 3/4 BHSCS	45	4	55771	BUMPER 1/2 OD X 1/4 TALL X 1/8 CENTER HOLE
10	1	20557	CONTROL SPEED SCR MM23001C	46	3	62944	SCREW 6-32 X 5/8 BHSCS
11	3	22351	(NOT SHOWN) WIRE 18 AWG 600V RED TYPE MTW	47	3	70657	TUBING HEAT SHRINK .75 ID 2:1 SHRINK RATIO CLEAR 50 FT SPOOL
12	9	22800	(NOT SHOWN) TUBE SHRINK .125 DIA BLACK	48	2	70901	TUBING HEAT SHRINK .19 ID 2:1 SHRINK RATIO
13	4	26468	SCREW 6-32 X 3/16 BHSCS	49	20	71021	(NOT SHOWN) WIRE 18 AWG BLUE TYPE MTW MIN. 600V 0.1 OD
14	7	26629	TERMINAL SPADE 16-14 AWG .250 X .032 FEMALE INSULATED	50	2	73782	(NOT SHOWN) VARISTOR 420VAC RMS 560VDC 4.5KA PEAK CURRENT 14MM DIA
15	9	27377	TERMINAL SPADE 90DEG 16-14AWG .250 FM INSUL	51	1	77568	LABEL PROTECTIVE EARTH 1/2" DIA
16	29	27571	(NOT SHOWN) WIRE 16 AWG GRN/YEL TYPE MTW	52	1	78593	LABEL WARNING - ELECTRICAL SHOCK/ELECTROCUTION 1.13" TRIANGLE
17	1	28060	NUT, 10-32 UNF KEPS	53	1	78824	LABEL WARNING - DO NOT EXPOSE TO WATER
18	2	29450	NUT 6-32 LOCKING STAR WASHER	54	1	78953	DISCONNECT SWITCH DOOR MOUNT IP55 16 AMP RED/YELLOW HANDLE
19	4	29458	WASHER #10 FLTW NYLON .031 THICK	55	1	79231	SWITCH 230V LOW-VOLTAGE DROPOUT
20	1	30081	LABEL VOLTAGE 230V (KB)	56	9	79316	WASHER #6 NYLON .15 ID X .32 OD X .03 BLACK
21	4	30828	SCREW 5-40 X 1/4 SHCS	57	1	79348	WASHER #10 NYLON .19 ID X .44 OD X .03 BLACK
22	4	32304	(NOT SHOWN) TERMINAL PIN 14-16 AWG	58	1	79574	TERMINAL SPADE 22-18 AWG .110 X .032 FEMALE INSULATED RED
23	1	32926	SEAL POTENTIOMETER HEXNUT .25 SHAFT 3/8-32 TH	59	11	79605	(NOT SHOWN) HOLDER CABLE TIE 3/4 X 3/4 3/16 CABLE TIE
24	1	33099	NUT CONDUIT 3/8 STEEL	60	4	79643	SCREW #8 X 5/8 SHEET METAL #2 SQUARE DRIVE
25	1	33182	POTENTIOMETER 10K LIN 1/4 SHAFT 3/8 BUSHING	61	84	79864	(NOT SHOWN) WIRE 14 AWG BRN TYPE MTW
26	4	34481	SCREW M5 X 0.8 X 12 mm BHSCS	62	81	79867	(NOT SHOWN) WIRE 14 AWG LT BLU TYPE MTW
27	1	34829	CORDSET CEE 7/7 STRAIGHT MOLDED PLUG 250V 16AMP 2.5M	63	1	80091	BRACKET CIRCUIT BREAKER CE SPEED CONTROLLER
28	34	35655	SEAL NEOPRENE SPONGE 3/8 X 5/32 ADHESIVE BACK	64	1	80337	FILTER RFI/EMI 16AMP 120/250VAC 50/60HZ
29	1	35766	KNOB POTENTIOMETER AL .75 DIA .25 SHAFT	65	2.5	81002	TUBING HEAT SHRINK 3:1 ADHESIVE 1.1 ID SHRINK TO .38 RED
30	1	35799	TERMINAL RING 22-16 #6/M3.5 STUD	66	1	82961	ENCLOSURE 230V BB3000 PL2000 CONTROLLER CE
31	17	36428	(NOT SHOWN) WIRE 16 AWG GRY TYPE MTW	67	1	82984	LEGEND PLATE BB3000 120/230V SPEED CONTROLLER
32	1	36718	CORDSET 3-POLE 13A FEMALE CONNECTOR 144 IN				
33	1	37739	CORD GRIP NONMETALLIC .17- .47 DIA X 1/2 NPT				
34	2	37749	WIRE TIE VELCRO 11 LONG				
35	1	37817	SCREW M3 X 0.5 X 12mm SHCS				
36	4	38324	TERMINAL SPADE FEMALE 90 DEG 12-10 AWG				

FIGURE 21 – P/N 79218 CONTROLLER 10 AMP 230 V 50/60 Hz CE MULTIPLE MODEL PARTS LIST

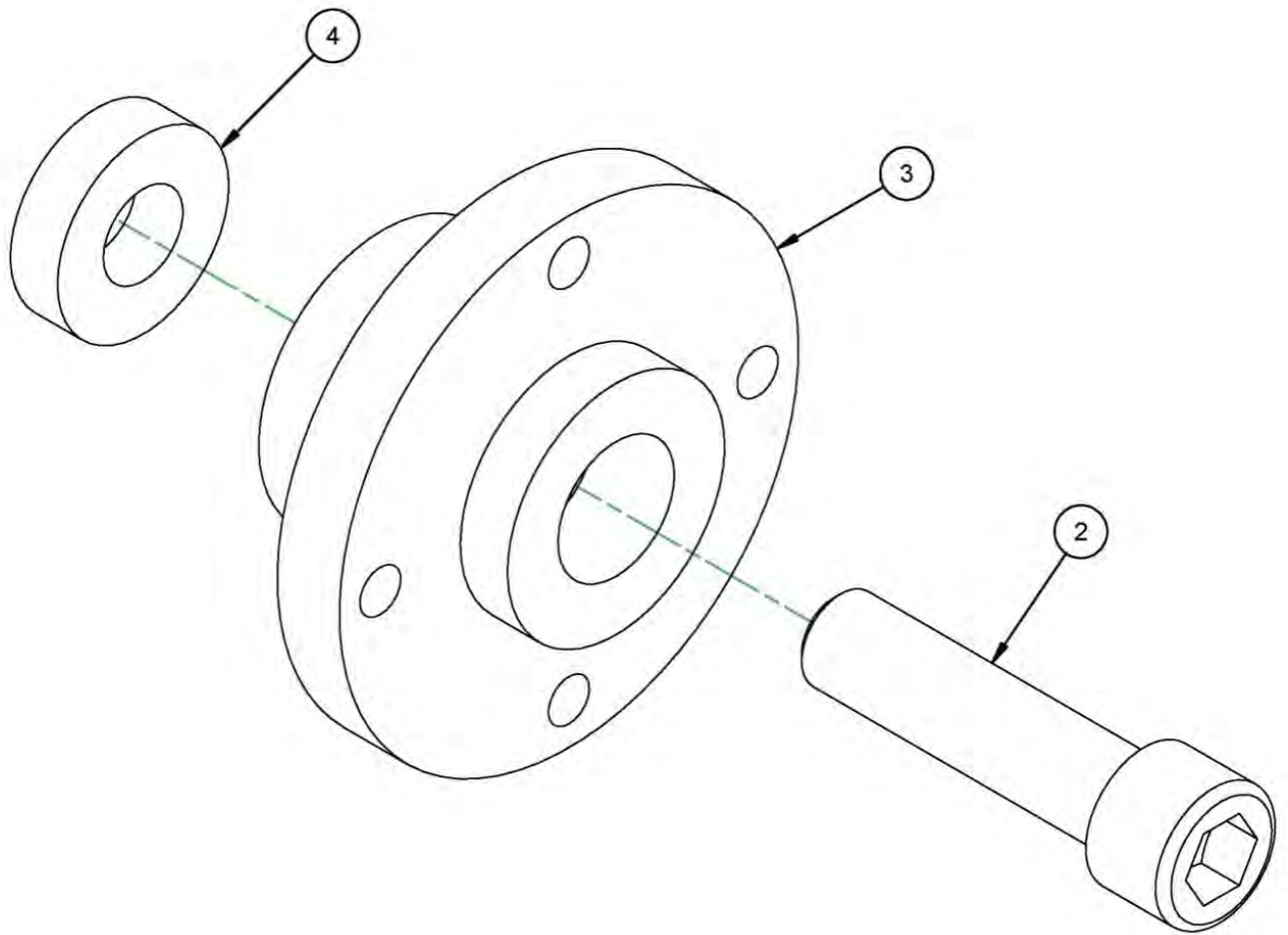

PARTS LIST			
ITEM	QTY	PART No.	DESCRIPTION
1	NS	11920	WRENCH HEX 1/2 SHORT ARM
2	1	13356	SCREW 5/8-11 X 2-1/2 SHCS
3	1	30571	ADAPTER SINGLE BOLT PL2000
4	1	31309	SPACER SINGLE BOLT ADAPTER

FIGURE 22 – P/N 30572 SINGLE BOLT ADAPTER ASSY

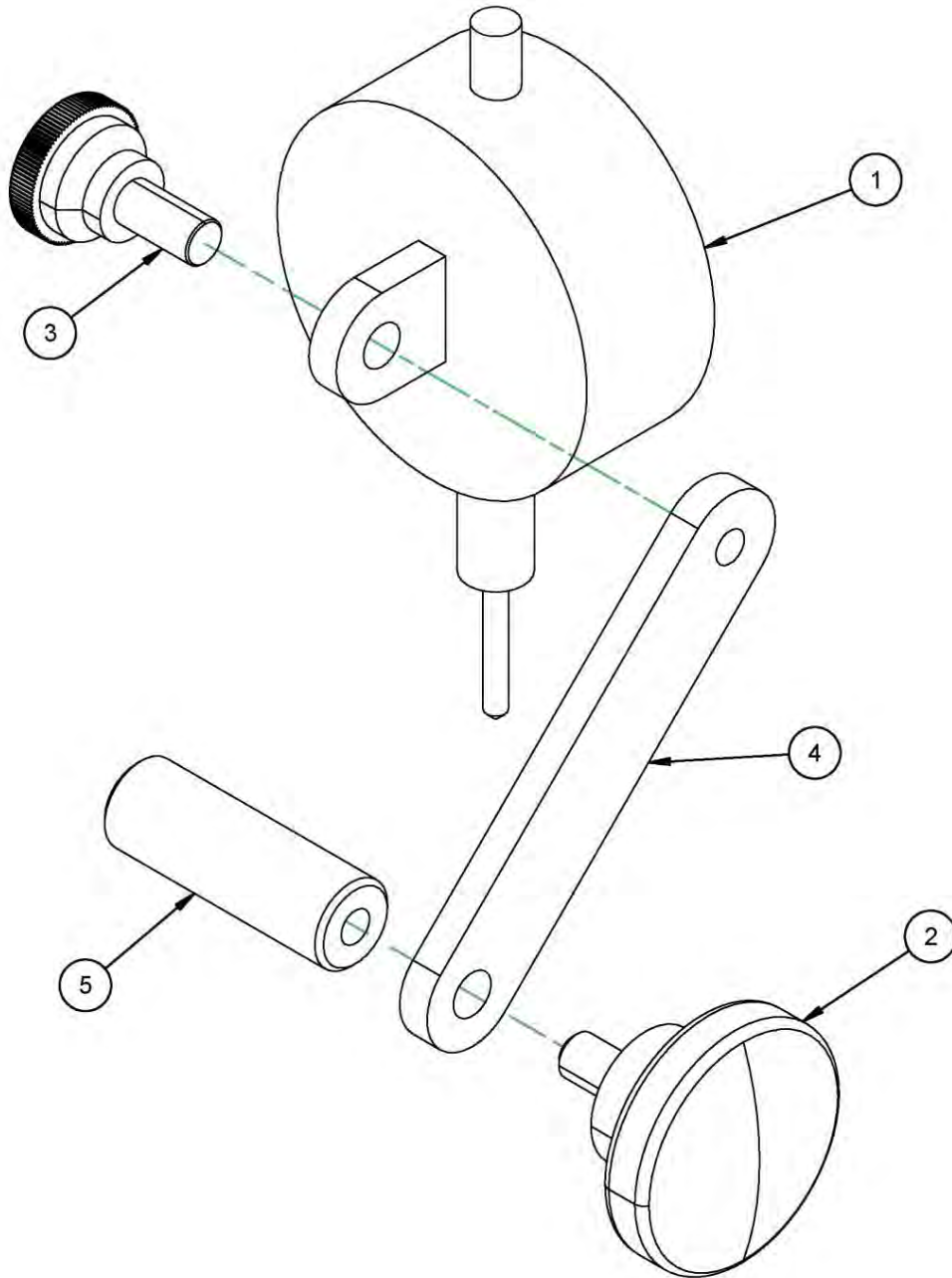

PARTS LIST			
ITEM	QTY	PART No.	DESCRIPTION
1	1	10580	INDICATOR DIAL .25 RANGE 0-50-0 .001 GRADUATION LUG MOUNT
2	1	10582	KNOB PLASTIC KNURLED
3	1	10583	KNOB PLASTIC KNURLED
4	1	10584	HOLDER DIAL INDICATOR
5	1	30621	STUD DIAL INDICATOR

FIGURE 23 – P/N 30407 INDICATOR ASSY PL2000

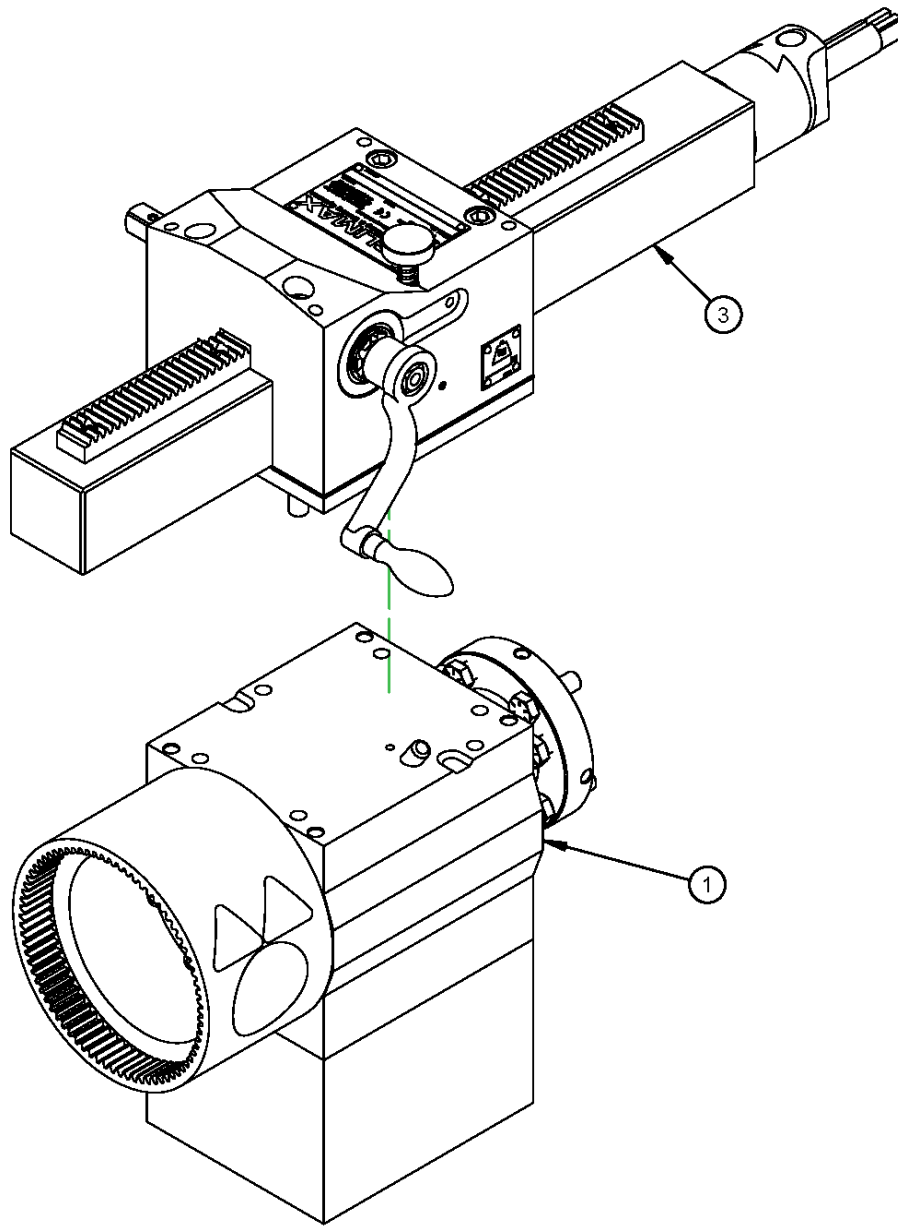

PARTS LIST			
ITEM	QTY	P/N:	DESCRIPTION
1	1	31586	ASSY MAIN BODY 2ND PL2000
2	1	31587	KIT TOOL PL2000 2ND (NOT SHOWN)
3	1	31594	BAR TURNING SUPPORT FEED ASSY 2ND

FIGURE 24 – P/N 31585 ASSY MAIN BODY & BAR ASSY 2ND PL2000

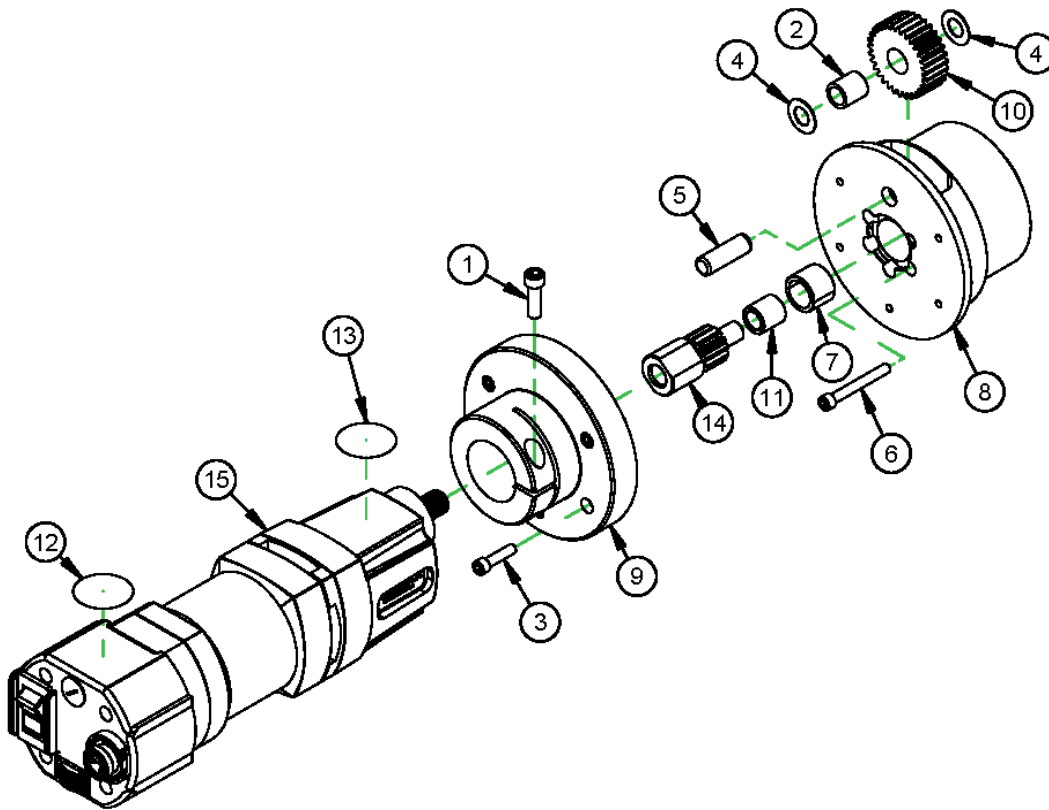

PARTS LIST		
ITEM	PART No.	DESCRIPTION
1	10431	SCREW 5/16-18 X 1 SHCS
2	10434	BRG NEEDLE 1/2 ID X 11/16 OD X .75 OPEN
3	11118	SCREW 1/4-20 X 1 SHCS
4	11736	WASHER THRUST .500 ID X .937 OD X .030
5	11832	PIN DOWEL 1/2 DIA X 1-1/2
6	12444	SCREW 1/4-20 X 2 SHCS
7	14239	BRG NEEDLE 3/4 ID X 1 OD X .75 OPEN
8	30302	HOUSING PLANETARY ELECTRIC
9	30303	MOUNT MOTOR ELECTRIC
10	30305	GEAR IDLER ELECTRIC 16DP 31TEETH 20PA X .75
11	30408	BRG RACE .500 ID X .750 OD X .780
NS	36549	CONTROL SPEED ASSY KM3000 120V 4TH GEN DOM (NOT SHOWN)
	79218	CONTROLLER BB3000 230V 50/60 HZ CE (NOT SHOWN)
12	59044	LABEL WARNING - CONSULT OPERATOR'S MANUAL
13	78824	LABEL WARNING - DO NOT EXPOSE TO WATER
14	79809	GEAR PINION ELECTRIC PL2000
15	81584	MOTOR MODIFIED 230V 1050W X 780 RPM REVERSIBLE PL2000
	81585	MOTOR MODIFIED 120V 1050W X 780 RPM REVERSIBLE PL2000

FIGURE 25 – P/N 30309 DRIVE ROTATIONAL PL2000 ELECTRIC 120V AND P/N 30816 DRIVE ROTATIONAL PL2000 230V

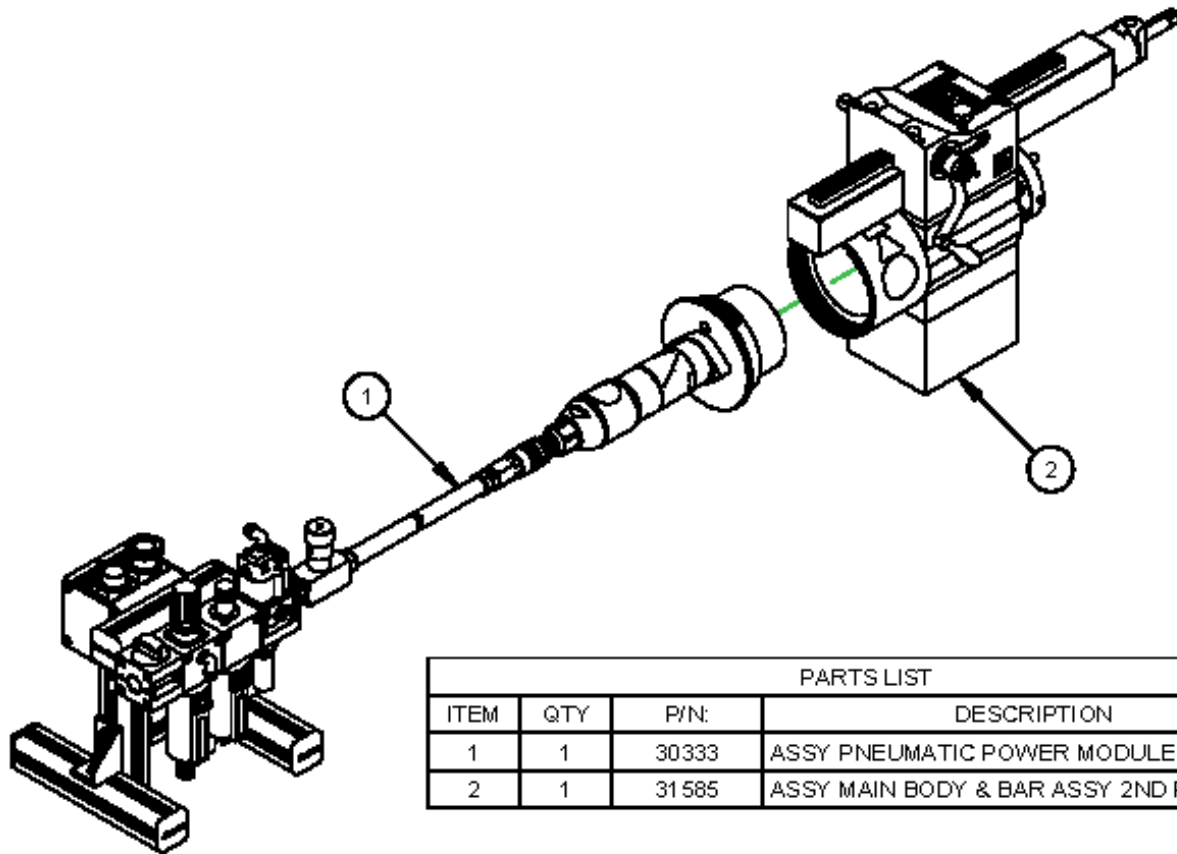

31584 - MODEL PL2000 PORTABLE LATHE AIR 2ND

FIGURE 26 – P/N 31584 MODEL PL2000 PORTABLE LATE AIR 2ND

APPENDIX A MSDS

Safety Data Sheet



Section 1: Identification of the substance or mixture and of the supplier

Product Name: Polytac® EP
SDS Number: 778593

Synonyms/Other Means of Identification: Polytac® EP No. 2

Intended Use: Lubricating Grease

Manufacturer: Phillips 66 Company
P. O. Box 4428
Houston, Texas 77210

Emergency Health and Safety Number: Chemtrec: 800-424-9300 (24 Hours)

Customer Service: U.S.: 1-800-822-6457 or International: +1-83-2486-3363

Technical Information: 1-877-445-9198

SDS Information: Phone: 800-762-0942
Email: SDS@P66.com
URL: www.Phillips66.com

Section 2: Hazard(s) Identification

This material is not considered hazardous according to OSHA criteria.



Section 3: Composition / Information on Ingredients

Component	CASRN	Concentration ¹
Lubricant Base Oil (Petroleum)	VARIOUS	>80
Calcium Carbonate	471-34-1	<15
Additives	Proprietary	<10

¹ All concentrations are percent by weight unless ingredient is a gas. Gas concentrations are in percent by volume.

Section 4: First Aid Measures

Eye Contact: If irritation or redness develops from exposure, flush eyes with clean water. If symptoms persist, seek medical attention.

Skin Contact: Remove contaminated shoes and clothing and cleanse affected area(s) thoroughly by washing with mild soap and water or a waterless hand cleaner. If irritation or redness develops and persists, seek medical attention. If product is injected into or under the skin, or into any part of the body, regardless of the appearance of the wound or its size, the individual should be evaluated immediately by a physician. (see Note to Physician)

Inhalation (Breathing): First aid is not normally required. If breathing difficulties develop, move victim away from source of exposure and into fresh air in a position comfortable for breathing. Seek immediate medical attention.

Ingestion (Swallowing): First aid is not normally required; however, if swallowed and symptoms develop, seek medical attention.

778593 - Polytac® EP
Date of Issue: 19-Jul-2012

Page 1/7
Status: FINAL

778593 - Polytac® EP
Date of Issue: 19-Jul-2012

Page 2/7
Status: FINAL

Notes to Physician: When using high-pressure equipment, injection of product under the skin can occur. In this case, the casualty should be sent immediately to hospital. Do not wait for symptoms to develop. High-pressure hydrocarbon injection injuries may produce substantial necrosis of underlying tissue despite an innocuous appearing external wound. These injuries often require extensive emergency surgical debridement and all injuries should be evaluated by a specialist in order to assess the extent of injury. Early surgical treatment within the first few hours may significantly reduce the ultimate extent of injury.

Medical Conditions Aggravated by Exposure: Conditions which may be aggravated by exposure include skin disorders.

Section 5: Fire-Fighting Measures

NFPA 704 Hazard Class

Health: 0 **Flammability:** 1 **Instability:** 0 (0-Minimal, 1-Slight, 2-Moderate, 3-Serious, 4-Severe)

Unusual Fire & Explosion Hazards: This material may burn, but will not ignite readily. If container is not properly cooled, it can rupture in the heat of a fire.

Extinguishing Media: Dry chemical, carbon dioxide, foam, or water spray is recommended. Water or foam may cause frothing of materials heated above 212°F / 100°C. Carbon dioxide can displace oxygen. Use caution when applying carbon dioxide in confined spaces. Simultaneous use of foam and water on the same surface is to be avoided as water destroys the foam.

Fire Fighting Instructions: For fires beyond the initial stage, emergency responders in the immediate hazard area should wear protective clothing. When the potential chemical hazard is unknown, in enclosed or confined spaces, a self contained breathing apparatus should be worn. In addition, wear other appropriate protective equipment as conditions warrant (see Section 8).

Isolate immediate hazard area and keep unauthorized personnel out. Stop spill/release if it can be done safely. Move undamaged containers from immediate hazard area if it can be done safely. Water spray may be useful in minimizing or dispersing vapors and to protect personnel. Cool equipment exposed to fire with water, if it can be done safely. Avoid spreading burning liquid with water used for cooling purposes.

Hazardous Combustion Products: Combustion may yield smoke, carbon monoxide, and other products of incomplete combustion. Oxides of sulfur, nitrogen or phosphorus may also be formed.

See Section 9 for Flammable Properties including Flash Point and Flammable (Explosive) Limits

Section 6: Accidental Release Measures

Personal Precautions: This material may burn, but will not ignite readily. Keep all sources of ignition away from spill/release. Stay upwind and away from spill/release. Avoid direct contact with material. For large spillages, notify persons down wind of the spill/release, isolate immediate hazard area and keep unauthorized personnel out. Wear appropriate protective equipment, including respiratory protection, as conditions warrant (see Section 8). See Sections 2 and 7 for additional information on hazards and precautionary measures.

Environmental Precautions: Stop spill/release if it can be done safely. Prevent spilled material from entering sewers, storm drains, other unauthorized drainage systems, and natural waterways. Use water sparingly to minimize environmental contamination and reduce disposal requirements. If spill occurs on water notify appropriate authorities and advise shipping of any hazard. Spills into or upon navigable waters, the contiguous zone, or adjoining shorelines that cause a sheen or discoloration on the surface of the water, may require notification of the National Response Center (phone number 800-424-8802).

Methods for Containment and Clean-Up: Notify relevant authorities in accordance with all applicable regulations. Immediate cleanup of any spill is recommended. Dike far ahead of spill for later recovery or disposal. Absorb spill with inert material such as sand or vermiculite, and place in suitable container for disposal. If spilled on water remove with appropriate methods (e.g. skimming, booms or absorbents). In case of soil contamination, remove contaminated soil for remediation or disposal, in accordance with local regulations.

Recommended measures are based on the most likely spillage scenarios for this material, however local conditions and regulations may influence or limit the choice of appropriate actions to be taken. See Section 13 for information on appropriate disposal.

Section 7: Handling and Storage

Precautions for safe handling: Keep away from flames and hot surfaces. Wash thoroughly after handling. Use good personal hygiene practices and wear appropriate personal protective equipment (see section 8).

High pressure injection of hydrocarbon fuels, hydraulic oils or greases under the skin may have serious consequences even though no symptoms or injury may be apparent. This can happen accidentally when using high pressure equipment such as high pressure grease guns, fuel injection apparatus or from pinhole leaks in tubing of high pressure hydraulic oil equipment.

Spills will produce extremely slippery surfaces. Do not enter confined spaces such as tanks or pits without following proper entry procedures such as ASTM D-4276 and 29CFR 1910.146. Do not wear contaminated clothing or shoes.

Conditions for safe storage: Keep container(s) tightly closed and properly labeled. Use and store this material in cool, dry, well-ventilated area away from heat and all sources of ignition. Store only in approved containers. Keep away from any incompatible material (see Section 10). Protect container(s) against physical damage.

"Empty" containers retain residue and may be dangerous. Do not pressurize, cut, weld, braze, solder, drill, grind, or expose such containers to heat, flame, sparks, or other sources of ignition. They may explode and cause injury or death. "Empty" drums should be completely drained, properly bunged, and promptly shipped to the supplier or a drum reconditioner. All containers should be disposed of in an environmentally safe manner and in accordance with governmental regulations. Before working on or in tanks which contain or have contained this material, refer to OSHA regulations, ANSI Z49.1, and other references pertaining to cleaning, repairing, welding, or other contemplated operations.

Section 8: Exposure Controls / Personal Protection

Component	ACGIH	OSHA	Other
Lubricant Base Oil (Petroleum)	TWA: 5mg/m ³ STEL: 10 mg/m ³ as oil mist, if generated	TWA: 5 mg/m ³ as Oil Mist, if generated	—
Calcium Carbonate	TWA: 10 mg/m ³	15 mg/m ³ (Total) TWA 5 mg/m ³ (Resp) TWA	—

Note: State, local or other agencies or advisory groups may have established more stringent limits. Consult an industrial hygienist or similar professional, or your local agencies, for further information.

Engineering controls: If current ventilation practices are not adequate to maintain airborne concentrations below the established exposure limits, additional engineering controls may be required.

Eye/Face Protection: The use of eye/face protection is not normally required, however, good industrial hygiene practice suggests the use of eye protection that meets or exceeds ANSI Z.87.1 whenever working with chemicals.

Skin/Hand Protection: The use of skin protection is not normally required, however, good industrial hygiene practice suggests the use of gloves or other appropriate skin protection whenever working with chemicals. Suggested protective materials: Nitrile

Respiratory Protection: Respiratory protection is not normally required under intended conditions of use. Emergencies or conditions that could result in significant airborne exposures may require the use of NIOSH approved respiratory protection. An industrial hygienist or other appropriate health and safety professional should be consulted for specific guidance under these situations.

Suggestions provided in this section for exposure control and specific types of protective equipment are based on readily available information. Users should consult with the specific manufacturer to confirm the performance of their protective equipment. Specific situations may require consultation with industrial hygiene, safety, or engineering professionals.

Section 9: Physical and Chemical Properties

Note: Unless otherwise stated, values are determined at 20°C (68°F) and 760 mm Hg (1 atm). Data represent typical values and are not intended to be specifications.

Appearance:	Green
Physical Form:	Semi-Solid
Odor:	Petroleum
Odor Threshold:	No data
pH:	Not applicable
Vapor Density (air=1):	> 5
Initial Boiling Point/Range:	No data

778593 - Polytac® EP
Date of Issue: 19-Jul-2012

Page 4/7
Status: FINAL

Melting/Freezing Point:	No data
Solubility in Water:	Insoluble
Partition Coefficient (n-octanol/water) (Kow):	No data
Bulk Density:	8.57 lb/gal @ 60 °F / 15 °C 1.0292 kg/m ³
Evaporation Rate (nBuAc=1):	<1
Flash Point:	> 400 °F / > 204 °C
Test Method:	Cleveland Open Cup (COC), ASTM D92
Lower Explosive Limits (vol % in air):	No data
Upper Explosive Limits (vol % in air):	No data
Auto-ignition Temperature:	No data

Section 10: Stability and Reactivity

Stability: Stable under normal ambient and anticipated conditions of use.

Conditions to Avoid: Extended exposure to high temperatures can cause decomposition. Avoid all possible sources of ignition.

Materials to Avoid (Incompatible Materials): Avoid contact with strong oxidizing agents and strong reducing agents.

Hazardous Decomposition Products: Not anticipated under normal conditions of use.

Hazardous Polymerization: Not known to occur.

Section 11: Toxicological Information

Information on Toxicological Effects of Substance/Mixture

Acute Toxicity	Hazard	Additional Information	LC50/LD50 Data
Inhalation	Inhalation is not anticipated		No Data
Skin Absorption	Unlikely to be harmful		> 2 g/kg (estimated)
Ingestion (Swallowing)	Unlikely to be harmful		> 5 g/kg (estimated)

Aspiration Hazard: Not expected to be an aspiration hazard.

Skin Corrosion/Irritation: Not expected to be irritating. Repeated exposure may cause skin dryness or cracking.

Serious Eye Damage/Irritation: Not expected to be irritating.

Signs and Symptoms: Inhalation of oil mists or vapors generated at elevated temperatures may cause respiratory irritation. Accidental ingestion can result in minor irritation of the digestive tract, nausea and diarrhea.

Skin Sensitization: No information available on the mixture, however none of the components have been classified for skin sensitization (or are below the concentration threshold for classification).

Respiratory Sensitization: No information available.

Specific Target Organ Toxicity (Single Exposure): No information available on the mixture, however none of the components have been classified for target organ toxicity (or are below the concentration threshold for classification).

Specific Target Organ Toxicity (Repeated Exposure): No information available on the mixture, however none of the components have been classified for target organ toxicity (or are below the concentration threshold for classification).

Carcinogenicity: No information available on the mixture, however none of the components have been classified for carcinogenicity (or are below the concentration threshold for classification).

Germ Cell Mutagenicity: No information available on the mixture, however none of the components have been classified for germ cell mutagenicity (or are below the concentration threshold for classification).

Reproductive Toxicity: No information available on the mixture, however none of the components have been classified for reproductive toxicity (or are below the concentration threshold for classification).

Information on Toxicological Effects of Components

Lubricant Base Oil (Petroleum)

Carcinogenicity: The petroleum base oils contained in this product have been highly refined by a variety of processes including severe hydrocracking/hydroprocessing to reduce aromatics and improve performance characteristics. All of the oils meet the IP-346 criteria of less than 3 percent PAH's and are not considered carcinogens by NTP, IARC, or OSHA.

Section 12: Ecological Information

Toxicity: Experimental studies on the base oil component of lubricating greases show that acute aquatic toxicity values are greater than 1000 mg/L. These values are consistent with the predicted aquatic toxicity of these substances based on their hydrocarbon compositions. However, there is insufficient information available on the toxicity of the thickening agents used in greases. They should be regarded as capable of causing long term adverse effects in the aquatic environment. Classification: No classified hazards.

Persistence and Degradability: The base oil constituents of greases are expected to be inherently, but not readily biodegradable. Some of the thickening agents may be readily biodegradable.

Bioaccumulative Potential: Log Kow values measured for the hydrocarbon components of this material range from 4 to greater than 6, and therefore are regarded as having the potential to bioaccumulate. In practice, metabolic processes may reduce bioconcentration.

Mobility in Soil: Volatilization to air is not expected to be a significant fate process due to the low vapor pressure of this material. Components may behave differently in the aquatic environment with soaps dispersing and dissolving to some extent in water while the hydrocarbons will float on the surface due to their low water solubility. The hydrocarbon portion would be expected to show low mobility in soil and water. The major environmental fate would be expected to be biodegradation.

Other Adverse Effects: None anticipated.

Section 13: Disposal Considerations

The generator of a waste is always responsible for making proper hazardous waste determinations and needs to consider state and local requirements in addition to federal regulations.

This material, if discarded as produced, would not be a federally regulated RCRA "listed" hazardous waste and is not believed to exhibit characteristics of hazardous waste. See Sections 7 and 8 for information on handling, storage and personal protection and Section 9 for physical/chemical properties. It is possible that the material as produced contains constituents which are not required to be listed in the MSDS but could affect the hazardous waste determination. Additionally, use which results in chemical or physical change of this material could subject it to regulation as a hazardous waste.

This material under most intended uses would become "Used Oil" due to contamination by physical or chemical impurities. Whenever possible, Recycle used oil in accordance with applicable federal and state or local regulations. Container contents should be completely used and containers should be emptied prior to discard.

Section 14: Transport Information

U.S. Department of Transportation (DOT)

Shipping Description: *Not regulated*
Note: *If shipped by land in a packaging having a capacity of 3,500 gallons or more, the provisions of 49 CFR, Part 130 apply. (Contains oil)*

International Maritime Dangerous Goods (IMDG)

Shipping Description: *Not regulated*
Note: *U.S. DOT compliance requirements may apply. See 49 CFR 171.22, 23 & 25.*

International Civil Aviation Org. / International Air Transport Assoc. (ICAO/IATA)

UN/ID #: *Not regulated*
Note: *U.S. DOT compliance requirements may apply. See 49 CFR 171.22, 23 & 24.*

	LTD. QTY	Passenger Aircraft	Cargo Aircraft Only
Packaging Instruction #:	---	---	---
Max. Net Qty. Per Package:	---	---	---

Section 15: Regulatory Information

778593 - Polytac® EP
 Date of Issue: 19-Jul-2012

Page 6/7
 Status: **FINAL**

CERCLA/SARA - Section 302 Extremely Hazardous Substances and TPQs (in pounds):
 This material does not contain any chemicals subject to the reporting requirements of SARA 302 and 40 CFR 372.

CERCLA/SARA - Section 311/312 (Title III Hazard Categories)

Acute Health: No
 Chronic Health: No
 Fire Hazard: No
 Pressure Hazard: No
 Reactive Hazard: No

CERCLA/SARA - Section 313 and 40 CFR 372:
 This material does not contain any chemicals subject to the reporting requirements of SARA 313 and 40 CFR 372.

EPA (CERCLA) Reportable Quantity (in pounds):
 This material does not contain any chemicals with CERCLA Reportable Quantities.

California Proposition 65:
 Warning: This material may contain detectable quantities of the following chemicals, known to the State of California to cause cancer, birth defects or other reproductive harm, and which may be subject to the warning requirements of California Proposition 65 (CA Health & Safety Code Section 25249.5).

Component	Type of Toxicity
Silica-Crystalline (Quartz)	Cancer

International Hazard Classification

GHS Classification
 None

Canada:
 This product has been classified in accordance with the hazard criteria of the Controlled Products Regulations (CPR) and the MSDS contains all the information required by the Regulations.

WHMIS Hazard Class:
 None

National Chemical Inventories
 All components are either listed on the US TSCA Inventory, or are not regulated under TSCA
 All components are either on the DSL, or are exempt from DSL listing requirements

U.S. Export Control Classification Number: EAR99

Section 16: Other Information

Date of Issue: 19-Jul-2012
 Status: **FINAL**
 Previous Issue Date: 30-Jul-2009
 Revised Sections or Basis for Revision: Manufacturer (Section 1)
 Format change
 Physical Properties (Section 9)
 Toxicological (Section 11)
 Regulatory information (Section 15)
 SDS Number: 778593

Guide to Abbreviations:

ACGIH = American Conference of Governmental Industrial Hygienists; CASRN = Chemical Abstracts Service Registry Number; CEILING = Ceiling Limit (15 minutes); CERCLA = The Comprehensive Environmental Response, Compensation, and Liability Act; EPA = Environmental Protection Agency; GHS = Globally Harmonized System; IARC = International Agency for Research on Cancer; INSHT = National Institute for Health and Safety at Work; IOPC = International Oil Pollution Compensation; LEL = Lower Explosive Limit; NE = Not Established; NFPA = National Fire Protection Association; NTP = National Toxicology Program; OSHA = Occupational Safety and Health Administration; PEL = Permissible Exposure Limit (OSHA); SARA = Superfund Amendments and Reauthorization Act; STEL = Short Term Exposure Limit (15 minutes); TLV = Threshold Limit Value (ACGIH); TWA = Time Weighted Average (8 hours); UEL = Upper Explosive Limit; WHMIS = Worker Hazardous Materials Information System (Canada)

Disclaimer of Expressed and implied Warranties:

The information presented in this Material Safety Data Sheet is based on data believed to be accurate as of the date this Material Safety Data Sheet was prepared. HOWEVER, NO WARRANTY OF MERCHANTABILITY, FITNESS FOR ANY PARTICULAR PURPOSE, OR ANY OTHER WARRANTY IS EXPRESSED OR IS TO BE IMPLIED REGARDING THE ACCURACY OR COMPLETENESS OF THE INFORMATION PROVIDED ABOVE, THE RESULTS TO BE OBTAINED FROM THE USE OF THIS INFORMATION OR THE PRODUCT, THE SAFETY OF THIS PRODUCT, OR THE HAZARDS RELATED TO ITS USE. No responsibility is assumed for any damage or injury resulting from abnormal use or from any failure to adhere to recommended practices. The information provided above, and the product, are furnished on the condition that the person receiving them shall make their own determination as to the suitability of the product for their particular purpose and on the condition that they assume the risk of their use. In addition, no authorization is given nor implied to practice any patented invention without a license.

550[®] NONMETALLIC ANTI-SEIZE COMPOUND

DESCRIPTION

550[®] Anti-Seize Compound is a premium formulation for a wide variety of applications over a wide temperature range. **550** is the ideal product for petrochemical plants' maintenance needs. Its homogeneous composition offers maximum protection against seizure and heat freeze, eases assembling and dismantling, and saves man hours. It assures protection against rust, oxidation, and corrosion. It will not harden, evaporate, or settle out; and it requires no thinning.

550 contains carefully balanced proportions of molybdenum disulfide (MoS₂), graphite, and low friction fillers in an aluminum complex base grease that is fortified with effective rust and corrosion inhibitors. Each principal anti-seize, low-friction ingredient has important properties and characteristics.

Molybdenum disulfide (MoS₂) has an affinity for ferrous metals, bonds itself to steel working surfaces and offers protection from frictional wear and fret corrosion while sustaining lubrication. Graphite provides extreme pressure characteristics.

The aluminum-complex base grease in **550** contains **JET-LUBE's CZ-EX[®]**, an extreme pressure additive. This package increases performance because it maintains the proper dispersion and suspension of solid ingredients.

- Lead Free
- Protects against seizure, heat freeze, galling, rust, and corrosion
- Lowers friction; reduces wrench torque
- Provides easy makeup and breakout
- Reduces maintenance costs
- Not affected by contraction, expansion, or vibration
- Will not run, drip, or settle out
- Color: Steel Blue

APPLICATIONS

Use **550** on:

Tubular	Threads	Flange Faces	Keyways/Keys
Gaskets	Slides	Guides	Fittings

Well suited for steel and aluminum. **550** works equally well on stainless steel, cast iron, titanium, copper, brass, alloys, plastic, and gasket materials. **550** is an effective anti-seize on LPG and other gases. For sealing applications, use **V-2[®]**.

NOTE: Not for use on oxygen lines.

CONFORMS TO: Military Specification MIL-PRF-907E	SERVICE RATING: -65°F (-54°C) to 2400°F (1316°C)
---	---

PRODUCT CHARACTERISTICS

Thickener	Aluminum Complex
Fluid Type	Petroleum
Color/Appearance	Steel Blue/Smooth Paste
Dropping Point (ASTM D-566)	450°F (232°C)
Specific Gravity	1.19
Density (lb/gal)	9.90
Oil Separation	<5.0
Wt. % Loss @ 212°F (100°C)	
Flash Point (ASTM D-92)	>430°F (221°C)
NLGI Grade	1 - 1½
Penetration @77°F (ASTM D-217)	300 - 330
K-Factor	0.17
1" B7 Studs @ 80,000 psi Contact Stress	
Copper Strip Corrosion (ASTM D-4048)	1A
4-Ball (ASTM D-2596)	
Weld Point, kgf	500
Load Wear Index	100
Salt Fog Resistance	+200
20% NaCl @ 100°F.	
Hrs. Free of Corrosion (ASTM B-117)	

PACKAGING

Code No.	Container Size	Container
15555	¼ lb.	Brush Top can
15502	½ lb.	Brush Top can
15504	1 lb.	Brush Top can
15507	2 lb.	Plug Top can
15523	10 lb.	Pail
15515	50 lb.	Pail
15524	150 lb.	Drum
15529	500 lb.	Drum

LIMITED WARRANTY

Jet-Lube, Inc. makes the Limited Express Warranty that at the date of delivery, this product shall be free from defects in Jet-Lube, Inc. materials and workmanship.

This Limited Express Warranty is expressly in lieu of any other express or implied warranties, including any implied warranty of merchantability or fitness for a particular purpose, and of any other obligation on the part of Jet-Lube, Inc.

The sole remedy for breach of the Limited Express Warranty shall be the refund of the purchase price. All other liability is negated and disclaimed, and Jet-Lube, Inc. shall not be liable for incidental or consequential damages.

CORPORATE LOCATIONS

Houston, Texas—World Headquarters

Maidenhead, England

Edmonton, Canada

JET-LUBE, INC.
4849 HOMESTEAD RD.,
P.O. BOX 21258 (77226-1258)
HOUSTON, TX 77028

WATS: 800-538-5823
PHONE: 713-674-7617
FAX: 713-678-4604
E-MAIL: sales@jetlube.com
www.jetlube.com

INDUSTRIAL

JET-LUBE, INC.

MATERIAL SAFETY DATA SHEET

I	Product Name: 550® NATO Stock Number: 8030-21-579-1625 (4 oz.) 8030-00-251-3980 (1 lb.) Chemical Family: Anti-seize (MIL-PRF-907E) and lubricant. Use: Equipment lubrication, lubricant for threaded connections or slides.	Manufacturer/Supplier: JET-LUBE, INC. Address: 4849 Homestead Rd., Ste. #200 Houston, TX, 77028 USA Phone: 713-674-7617 Emergency Phone: 713-674-7617 Fax: 713-678-4604 Chemtrec 24 hours (USA): 800-424-9300																		
II	<table border="1" style="width: 100%; border-collapse: collapse;"> <thead> <tr> <th style="width: 30%;">Hazardous Components</th> <th style="width: 20%;">CAS No.</th> <th style="width: 10%;">Wt%</th> <th style="width: 15%;">OSHA PEL</th> <th style="width: 15%;">ACGIH TLV</th> <th style="width: 10%;">Other Limits of Exposure</th> </tr> </thead> <tbody> <tr> <td>Petroleum oil</td> <td>64742525/64742014</td> <td>40-60</td> <td>Oil mist TWA-5mg/m³</td> <td>N/A</td> <td>STEL: 10mg/M³</td> </tr> <tr> <td>Nonhazardous Blend</td> <td>1317335/82980549 1317653/1314132 7782425</td> <td>40-60</td> <td>UN</td> <td>UN</td> <td>UN</td> </tr> </tbody> </table>	Hazardous Components	CAS No.	Wt%	OSHA PEL	ACGIH TLV	Other Limits of Exposure	Petroleum oil	64742525/64742014	40-60	Oil mist TWA-5mg/m ³	N/A	STEL: 10mg/M ³	Nonhazardous Blend	1317335/82980549 1317653/1314132 7782425	40-60	UN	UN	UN	
Hazardous Components	CAS No.	Wt%	OSHA PEL	ACGIH TLV	Other Limits of Exposure															
Petroleum oil	64742525/64742014	40-60	Oil mist TWA-5mg/m ³	N/A	STEL: 10mg/M ³															
Nonhazardous Blend	1317335/82980549 1317653/1314132 7782425	40-60	UN	UN	UN															
III	Main Hazards—Health Effects Eyes: May cause irritation. Inhalation: Viscous nature may block breathing passages if inhaled. Ingestion: May cause diarrhea. Skin: For hypersensitive persons, may irritate the skin after prolonged periods of contact.																			
IV	Eyes: Flush with water until all residual material is gone. If irritation persists, seek medical help. Inhalation: Clear air passage. If respiratory difficulty continues, seek medical help. Ingestion: Wash out mouth immediately. Consult physician. Skin: Wash thoroughly with hand cleanser, followed by soap & water. Contaminated clothing should be dry cleaned before reuse.																			
V	Extinguishing Media: Foam, dry powder, Halon®, carbon dioxide, sand, earth & water mist. Unsuitable Extinguishing Media: Water jet. Protective Equipment for Fire fighting: Self-contained breathing apparatus.																			
VI	Personal Precautions: Wear gloves & protective overalls. Environmental Precautions: Do not allow it to enter drains. Spillage: Scrape up bulk, then wipe up remainder with cloth. To prevent walking hazard, pick up remaining residue with diatomaceous earth.																			
VII	Handling: No special handling precautions necessary. Storage: Do not store at elevated temperatures.																			
VIII	Respiratory Protection: None needed. Hand Protection: Protective gloves for hypersensitive persons. Eye Protection: Glasses, if applied to parts in motion. Body Protection: Overalls.																			
IX	Physical State: Semisolid paste Color: Steel Blue Odor: Slight pH: Neutral Boiling Range/Point °F (°C): <600 (316) Melting Point °F (°C): >450 (232) Flash Point (COC) °F (°C): 430 (221) Autoignition Temperature °F (°C): >500 (260) Explosive Properties: LEL: 0.9% UEL: 7% Evaporation Rate (Butyl Acetate): <0.01 Partition Coefficient (Log Pow): N/A Vapor Pressure (kPa): <0.01 Percent Volatiles: Nil Density (g/cm³): 1.19 Flammability: Not flammable at ambient temperature. OAR Value: N/A Oxidizing Properties: None Water Solubility: Slight Vapor Density: >4.8																			
X	Stability: Chemically stable under normal conditions. No photoreactive agents. Conditions to Avoid: Powerful sources of ignition and extreme temperatures. Materials to Avoid: Strong inorganic & organic acids, oxidizing agents. Hazardous Decomposition Products: Burning generates smoke, airborne soot, hydrocarbons and oxides of carbon and sulfur. Burning aerosol could result in halogenated by-products. Residue mainly comprised of soot & mineral oxides.																			
XI	Acute Toxicity: Not known. Irritancy—Skin: Very mild. Skin Sensitization: Not known. Genotoxicity: None known. Subacute/Sub-chronic Toxicity: Not known. Chronic Toxicity: None known. Carcinogen: NTP: No IARC: No OSHA: No California Prop 65: N/A EC Class (67/548/EEC): No LC-50: >2000mg/l-extrapolated from component data. LD-50: N/A Allergens: None known.																			
XII	Possible Effects: In extreme cases, may generate oil fractions that could act as a marine pollutant. Occurrences of this nature are highly unlikely. Behavior: Relatively well behaved. Bioaccumulation potential nil. Environmental Fate: Highly unlikely to cause wide-spread contamination. Nontoxic to marine or land organisms.																			
XIII	Product Disposal: Do not incinerate. Contact waste disposal company or local authority for advice. Container Disposal: Pails without liner—see Product Disposal section above. Pails with plastic liner— pail may only be disposed of via standard waste disposal services, recycled or reused. Liner— see Product Disposal section above.																			
XIV	DOT: Consumer Commodity ORM-D UN No.: Bulk Nonhazardous Aero 1950, Class 2.2 Air Transport (ICAO & IATA): Bulk Nonhazardous Aero Hazardous-pressurized container Sea Transport (IMO & IMDG): Bulk Nonhazardous Aero 1950, Class 2.2 Road & Rail Transport (ADR/RID): Bulk Nonhazardous Aero Class 2.2, Aerosols																			
XV	Labeling Information: None needed EC Annex 1 Classification: Not Applicable. R Phrases: R22—harmful if swallowed. S Phrases: None applicable, as known. Ozone Depleting Chemicals: Not applicable. TSCA: All components are listed. WHMIS (Canada): Bulk Not controlled. Aero Class A, B-5 Canadian DSL: All components listed. 40 CFR Part 372 (SARA 313): N/A CERCLA: Nonhazardous RCRA Hazard Class: Nonhazardous SARA 311/312: None TSCA 12B Components: None																			
XVI	SDS first issued. SDS data revised. New Jersey Right to Know: See Section II																			

Signature: 
 Prepared by: Donald A. Oldiges
 Date Issued: June 1, 2008

As of issue date, the information contained herein is accurate and reliable to the best of JET-LUBE'S knowledge. JET-LUBE® does not warrant or guarantee its accuracy or reliability and shall not be liable for any loss or damage arising out of the use thereof. It is the user's responsibility to satisfy itself that the information offered for its consideration is suitable for its particular use.

LEGEND	
I.	IDENTIFICATION OF THE SUBSTANCE/PREPARATION AND COMPANY
II.	COMPOSITION INFORMATION ON INGREDIENTS
III.	HAZARDS IDENTIFICATION
IV.	FIRST AID MEASURES
V.	FIRE FIGHTING MEASURES
VI.	ACCIDENTAL RELEASE MEASURES
VII.	HANDLING AND STORAGE
VIII.	EXPOSURE CONTROL/PERSONAL PROTECTION
IX.	PHYSICAL AND CHEMICAL PROPERTIES
X.	STABILITY AND REACTIVITY
XI.	TOXICOLOGICAL INFORMATION
XII.	ECOLOGICAL INFORMATION
XIII.	WASTE DISPOSAL
XIV.	TRANSPORT INFORMATION
XV.	REGULATORY INFORMATION
XVI.	OTHER INFORMATION

HMIS SYMBOL

HEALTH	1
FLAMMABILITY	1
REACTIVITY	0
PPI	N/A

NFPA SYMBOL

FIRE			
1		1	
1	0	0	REACTIVITY
N/A			
PERSONAL PROTECTION INDEX			



Koolkut® Spectrum

Material Safety Data Sheet

1. Product and Company Identification

Product Name:	Koolkut® Spectrum
MSDS Number:	778731
Intended Use:	Metalworking Fluid
Manufacturer/Supplier:	ConocoPhillips Lubricants 600 N. Dairy Ashford Houston, Texas 77079-1175
Emergency Health and Safety Number:	Chemtrec: 800-424-9300 (24 Hours)
Customer Service:	888-766-7676
Technical Information:	800-255-9556
MSDS Information:	Internet: http://w3.conocophillips.com/NetMSDS/

2. Hazards Identification

<u>Emergency Overview</u>	<u>NFPA</u>
May be harmful to breastfed babies	

Appearance: Amber
Physical Form: Liquid
Odor: Petroleum

Potential Health Effects

Eye: Contact may cause mild eye irritation including stinging, watering, and redness.

Skin: Contact may cause mild skin irritation including redness and a burning sensation. Prolonged or repeated contact can defat the skin, causing drying and cracking of the skin, and possibly dermatitis (inflammation). No information available on skin absorption.

Inhalation (Breathing): No information available on acute toxicity.

Ingestion (Swallowing): Low to moderate degree of toxicity by ingestion.

Signs and Symptoms: Effects of overexposure may include irritation of the digestive tract, nausea and diarrhea. Inhalation of oil mist or vapors at elevated temperatures may cause respiratory irritation.

Pre-Existing Medical Conditions: Conditions which may be aggravated by exposure include skin disorders.

See Section 11 for additional Toxicity Information.

3. Composition / Information on Ingredients

Component	CASRN	Concentration*
Lubricant Base Oil (Petroleum)	VARIOUS	>90
Chlorinated Paraffins (C14-C17)	61788-76-9	<5
Additives	PROPRIETARY	<5

* All concentrations are percent by weight unless ingredient is a gas. Gas concentrations are in percent by volume.

4. First Aid Measures

Eye Contact: If irritation or redness develops from exposure, flush eyes with clean water. If symptoms persist, seek medical attention.

Skin Contact: Remove contaminated shoes and clothing and cleanse affected area(s) thoroughly by washing with mild soap and water or a waterless hand cleaner. If irritation or redness develops and persists, seek medical attention.

Inhalation (Breathing): If respiratory symptoms develop, move victim away from source of exposure and into fresh air in a position comfortable for breathing. If symptoms persist, seek medical attention.

Ingestion (Swallowing): If swallowed, seek emergency medical attention. If victim is drowsy or unconscious and vomiting, place on the left side with the head down and do not give anything by mouth. If victim is conscious and alert and ingestion occurred within the last hour, vomiting should be induced for ingestions of large amounts (more than 5 ounces in an adult) preferably under direction from a physician or poison center. Do not leave victim unattended and observe closely for adequacy of breathing.

Notes to Physician: Acute aspirations of large amounts of oil-laden material may produce a serious aspiration pneumonia. Patients who aspirate these oils should be followed for the development of long-term sequelae. Inhalation exposure to oil mists below current workplace exposure limits is unlikely to cause pulmonary abnormalities.

5. Fire-Fighting Measures

NFPA 704 Hazard Class

Health: 0 Flammability: 1 Instability: 0 (0-Minimal, 1-Slight, 2-Moderate, 3-Serious, 4-Severe)

OSHA Flammability Category: None

Unusual Fire & Explosion Hazards: This material may burn, but will not ignite readily. If container is not properly cooled, it can rupture in the heat of a fire.

Extinguishing Media: Dry chemical, carbon dioxide, foam, or water spray is recommended. Water or foam may cause frothing of materials heated above 212 F. Carbon dioxide can displace oxygen. Use caution when applying carbon dioxide in confined spaces.

Fire Fighting Instructions: For fires beyond the incipient stage, emergency responders in the immediate hazard area should wear protective clothing. When the potential chemical hazard is unknown, in enclosed or confined spaces, a self contained breathing apparatus should be worn. In addition, wear other appropriate protective equipment as conditions warrant (see Section 8).

Isolate immediate hazard area and keep unauthorized personnel out. Stop spill/release if it can be done safely. Move undamaged containers from immediate hazard area if it can be done safely. Water spray may be useful in minimizing or dispersing vapors and to protect personnel. Cool equipment exposed to fire with water, if it can be done safely. Avoid spreading burning liquid with water used for cooling purposes.

Hazardous Combustion Products: Combustion may yield smoke, carbon monoxide, and other products of incomplete combustion. Oxides of sulfur, nitrogen or phosphorus may also be formed.

See Section 9 for Flammable Properties including Flash Point and Flammable (Explosive) Limits

6. Accidental Release Measures

Personal Precautions: This material may burn, but will not ignite readily. Keep all sources of ignition away from spill/release. The use of explosion-proof electrical equipment is recommended. Stay upwind and away from spill/release. Notify persons down wind of the spill/release, isolate immediate hazard area and keep unauthorized personnel out. Wear appropriate protective equipment, including respiratory protection, as conditions warrant (see Section 8). See Sections 2 and 7 for additional information on hazards and precautionary measures.

Environmental Precautions: Stop spill/release if it can be done safely. Prevent spilled material from entering sewers, storm drains, other unauthorized drainage systems, and natural waterways. Use water sparingly to minimize environmental contamination and reduce disposal requirements. Spills into or upon navigable waters, the contiguous zone, or adjoining shorelines that cause a sheen or discoloration on the surface of the water, may require notification of the National Response Center (phone number 800-424-8802).

Methods for Containment and Clean-Up: Notify relevant authorities in accordance with all applicable regulations. Immediate cleanup of any spill is recommended. Dike far ahead of spill for later recovery or disposal. Absorb spill with inert material such as sand or vermiculite, and place in suitable container for disposal.

7. Handling and Storage

Precautions for safe handling: Wash thoroughly after handling. Use good personal hygiene practices and wear appropriate personal protective equipment.

Do not enter confined spaces such as tanks or pits without following proper entry procedures such as ASTM D-4276 and 29CFR 1910.146. Do not wear contaminated clothing or shoes.

"Empty" containers retain residue and may be dangerous. Do not pressurize, cut, weld, braze, solder, drill, grind, or expose such containers to heat, flame, sparks, or other sources of ignition. They may explode and cause injury or death. "Empty" drums should be completely drained, properly bunged, and promptly shipped to the supplier or a drum reconditioner. All containers should be disposed of in an environmentally safe manner and in accordance with governmental regulations. Before working on or in tanks which contain or have contained this material, refer to OSHA regulations, ANSI Z49.1, and other references pertaining to cleaning, repairing, welding, or other contemplated operations.

Conditions for safe storage: Keep container(s) tightly closed. Use and store this material in cool, dry, well-ventilated area away from heat and all sources of ignition. Store only in approved containers. Keep away from any incompatible material (see Section 10). Protect container(s) against physical damage.

8. Exposure Controls / Personal Protection

Component	US-ACGIH	OSHA	Other
Lubricant Base Oil (Petroleum)	TWA: 5mg/m ³ STEL: 10 mg/m ³ as Oil Mist, if generated	TWA: 5 mg/m ³ as Oil Mist, if generated	---

Note: State, local or other agencies or advisory groups may have established more stringent limits. Consult an industrial hygienist or similar professional, or your local agencies, for further information.

Engineering controls: If current ventilation practices are not adequate to maintain airborne concentrations below the established exposure limits, additional engineering controls may be required.

Eye/Face Protection: The use of eye protection that meets or exceeds ANSI Z 87.1 is recommended to protect against potential eye contact, irritation, or injury. Depending on conditions of use, a face shield may be necessary.

Skin/Hand Protection: The use of gloves impervious to the specific material handled is advised to prevent skin contact. Users should check with manufacturers to confirm the breakthrough performance of their products. Suggested protective materials: Nitrile.

Respiratory Protection: Where there is potential for airborne exposure above the exposure limit a NIOSH certified air purifying respirator equipped with R or P95 filters may be used.

A respiratory protection program that meets or is equivalent to OSHA 29 CFR 1910.134 and ANSI Z88.2 should be followed whenever workplace conditions warrant a respirator's use. Air purifying respirators provide limited protection and cannot be used in atmospheres that exceed the maximum use concentration (as directed by regulation or the manufacturer's instructions), in oxygen deficient (less than 19.5 percent oxygen) situations, or under conditions that are immediately dangerous to life and health (IDLH).

Suggestions provided in this section for exposure control and specific types of protective equipment are based on readily available information. Users should consult with the specific manufacturer to confirm the performance of their protective equipment. Specific situations may require consultation with industrial hygiene, safety, or engineering professionals.

9. Physical and Chemical Properties

Note: Unless otherwise stated, values are determined at 20°C (68°F) and 760 mm Hg (1 atm). Data represent typical values and are not intended to be specifications.

Appearance:	Amber
Physical Form:	Liquid
Odor:	Petroleum
Odor Threshold:	No data
pH:	Not applicable
Vapor Pressure:	<1 mm Hg
Vapor Density (air=1):	>1
Boiling Point/Range:	No data
Melting/Freezing Point:	<-4°F / <-20°C
Solubility in Water:	Insoluble
Partition Coefficient (n-octanol/water) (Kow):	No data
Specific Gravity:	0.89 @ 60°F (15.6°C)
Bulk Density:	7.4 lbs/gal
Viscosity:	5.4 cSt @ 100°C; 32 cSt @ 40°C
Evaporation Rate (nBuAc=1):	No data
Flash Point:	>399°F / >204°C
Test Method:	Cleveland Open Cup (COC), ASTM D92
LEL (vol % in air):	No data
UEL (vol % in air):	No data
Autoignition Temperature:	No data

10. Stability and Reactivity

Stability: Stable under normal ambient and anticipated conditions of use.

Conditions to Avoid: Extended exposure to high temperatures can cause decomposition.

Materials to Avoid (Incompatible Materials): Avoid contact with strong oxidizing agents and strong reducing agents.

Hazardous Decomposition Products: Not anticipated under normal conditions of use.

Hazardous Polymerization: Not known to occur.

11. Toxicological Information

Chronic Data:

A mortality study sponsored by General Motors and the United Auto Workers suggested a link between cutting oils or machining fluids and various forms of cancer (e.g., esophageal, laryngeal, and rectal). The study evaluated workplace exposures from 1940-1984. Since the composition of these materials has changed substantially since 1940, and because the most notable effects were seen among those with work histories dating back to that time, the relevance of these findings to present-day exposures is uncertain. Cutting oils or machining fluids have not been identified as carcinogens by NTP, IARC, or OSHA.

Lubricant Base Oil (Petroleum)

Carcinogenicity: The petroleum base oils contained in this product have been highly refined by a variety of processes including severe hydrocracking/hydroprocessing to reduce aromatics and improve performance characteristics. All of the oils meet the IP-346 criteria of less than 3 percent PAH's and are not considered carcinogens by NTP, IARC, or OSHA.

Chlorinated Paraffins (C14-C17)

Carcinogenicity: Certain Chlorinated paraffins mixtures have caused an increase in tumors when given in very high oral doses to mice and rats. This particular chlorinated paraffin has not been identified as a carcinogen by NTP, IARC or OSHA.

Target Organs: Administration of intermediate length chlorinated paraffins has demonstrated limited evidence of liver toxicity in experimental animals. Effects seen include increased liver:body weight ratios and hepatocellular hypertrophy.

Reproductive: Animal studies in both rats (up to 5000 mg/kg, orally) and rabbits (up to 100 mg/kg), orally did not demonstrate effects on the developing fetus. However, the rat studies found increased mortality in pups exposed to chlorinated paraffins via lactation.

Acute Data:

Component	Oral LD50	Dermal LD50	Inhalation LC50
Lubricant Base Oil (Petroleum)	>5 g/kg	>2 g/kg	No data
Chlorinated Paraffins (C14-C17)	>4 g/kg (rat)	>10 ml/kg (rabbit)	No Data

12. Ecological Information

Ecotoxicity: Experimental studies show that acute aquatic toxicity values are greater than 1000 mg/l. These values are consistent with the predicted aquatic toxicity of these substances based on their hydrocarbon compositions.

Mobility: Volatilization to air is not expected to be a significant fate process due to the low vapor pressure of this material. In water, base oils will float and spread over the surface at a rate dependent upon viscosity. There will be significant removal of hydrocarbons from the water by sediment adsorption. In soil and sediment, hydrocarbon components will show low mobility with adsorption to sediments being the predominant physical process. The main fate process is expected to be slow biodegradation of base oil components in soil and sediment.

Persistence and degradability: The hydrocarbons in this material are not readily biodegradable, but since they can be degraded by microorganisms, they are regarded as inherently biodegradable.

Bioaccumulation Potential: Log Kow values measured for the hydrocarbon components of this material range from 4 to over 6, and therefore regarded as having the potential to bioaccumulate. In practice, metabolic processes may reduce bioconcentration.

13. Disposal Considerations

The generator of a waste is always responsible for making proper hazardous waste determinations and needs to consider state and local requirements in addition to federal regulations.

This material, if discarded as produced, would not be a federally regulated RCRA "listed" hazardous waste and is not believed to exhibit characteristics of hazardous waste. See Sections 7 and 8 for information on handling, storage and personal protection and Section 9 for physical/chemical properties. It is possible that the material as produced contains constituents which are not required to be listed in the MSDS but could affect the hazardous waste determination. Additionally, use which results in chemical or physical change of this material could subject it to regulation as a hazardous waste.

This material under most intended uses would become "Used Oil" due to contamination by physical or chemical impurities. Whenever possible, Recycle Used Oil in accordance with applicable federal and state or local regulations. Container contents should be completely used and containers should be emptied prior to discard.

14. Transportation Information

U.S. Department of Transportation (DOT)

Shipping Description: *Not regulated*
Note: *If shipped by land in a packaging having a capacity of 3,500 gallons or more, the provisions of 49 CFR, Part 130 apply. (Contains oil)*

International Maritime Dangerous Goods (IMDG)

Shipping Description: *Not regulated*
Note: *U.S. DOT compliance requirements may apply. See 49 CFR 171.22, 23 & 25.*

International Civil Aviation Org. / International Air Transport Assoc. (ICAO/IATA)

UN/ID #: *Not regulated*
Note: *U.S. DOT compliance requirements may apply. See 49 CFR 171.22, 23 & 24.*

	LTD. QTY	Passenger Aircraft	Cargo Aircraft Only
Packaging Instruction #:	---	---	---
Max. Net Qty. Per Package:	---	---	---

15. Regulatory Information

CERCLA/SARA - Section 302 Extremely Hazardous Substances and TPQs (in pounds):
 This material does not contain any chemicals subject to the reporting requirements of SARA 302 and 40 CFR 372.

CERCLA/SARA - Section 311/312 (Title III Hazard Categories)
 Acute Health: No

Chronic Health: No
Fire Hazard: No
Pressure Hazard: No
Reactive Hazard: No

CERCLA/SARA - Section 313 and 40 CFR 372:

This material does not contain any chemicals subject to the reporting requirements of SARA 313 and 40 CFR 372.

EPA (CERCLA) Reportable Quantity (in pounds):

This material does not contain any chemicals with CERCLA Reportable Quantities.

California Proposition 65:

This product does not contain any chemicals which are known to the State of California to cause cancer, birth defects or other reproductive harm at concentrations that trigger the warning requirements of California Proposition 65.

Canadian Regulations:

This product has been classified in accordance with the hazard criteria of the Controlled Products Regulations (CPR) and the MSDS contains all the information required by the Regulations.

WHMIS Hazard Class

None

National Chemical Inventories:

All components are either listed on the US TSCA Inventory, or are not regulated under TSCA. All components are either on the DSL, or are exempt from DSL listing requirements.

U.S. Export Control Classification Number: EAR99

16. Other Information

Date of Issue: 15-Oct-2008
Status: Final
Previous Issue Date: 20-Jun-2007
Revised Sections or Basis for Revision: Emergency Overview (Section 2)
Toxicological (Section 11)
MSDS Number: 778731

Guide to Abbreviations:

ACGIH = American Conference of Governmental Industrial Hygienists; CASRN = Chemical Abstracts Service Registry Number; CEILING = Ceiling Limit (15 minutes); CERCLA = The Comprehensive Environmental Response, Compensation, and Liability Act; EPA = Environmental Protection Agency; IARC = International Agency for Research on Cancer; LEL = Lower Explosive Limit; NE = Not Established; NFPA = National Fire Protection Association; NTP = National Toxicology Program; OSHA = Occupational Safety and Health Administration; PEL = Permissible Exposure Limit (OSHA); SARA = Superfund Amendments and Reauthorization Act; STEL = Short Term Exposure Limit (15 minutes); TLV = Threshold Limit Value (ACGIH); TWA = Time Weighted Average (8 hours); UEL = Upper Explosive Limit; WHMIS = Worker Hazardous Materials Information System (Canada)

Disclaimer of Expressed and implied Warranties:

The information presented in this Material Safety Data Sheet is based on data believed to be accurate as of the date this Material Safety Data Sheet was prepared. HOWEVER, NO WARRANTY OF MERCHANTABILITY, FITNESS FOR ANY PARTICULAR PURPOSE, OR ANY OTHER WARRANTY IS EXPRESSED OR IS TO BE IMPLIED REGARDING THE ACCURACY OR COMPLETENESS OF THE INFORMATION PROVIDED ABOVE, THE RESULTS TO BE OBTAINED FROM THE USE OF THIS INFORMATION OR THE PRODUCT, THE SAFETY OF THIS PRODUCT, OR THE HAZARDS RELATED TO ITS USE. No responsibility is assumed for any damage or injury resulting from abnormal use or from any failure to adhere to recommended practices. The information provided above, and the product, are furnished on the condition that the person receiving them shall make their own determination as to the suitability of the product for their particular purpose and on the condition that they assume the risk of their use. In addition, no authorization is given nor implied to practice any patented invention without a license.

(MSDS: 722330)

Page 1 of 7



MATERIAL SAFETY DATA SHEET

76 Unax AW 32, 46, 68

1. PRODUCT AND COMPANY IDENTIFICATION

Product Name: 76 Unax AW 32, 46, 68
Product Code: 4641032000, 4642046000, 4643068000
Synonyms: 76 Unax AW 32
 76 Unax AW 46
 76 Unax AW 68
Intended Use: Industrial oil
Chemical Family: Petroleum hydrocarbon
Responsible Party: 76 Lubricants
 A Division of ConocoPhillips
 600 N. Dairy Ashford
 Houston, TX 77079-1175
For Additional MSDSs 800-762-0942
Technical Information: 800-435-7761

The intended use of this product is indicated above. If any additional use is known, please contact us at the Technical Information number listed.

EMERGENCY OVERVIEW

24 Hour Emergency Telephone Numbers:

Spill, Leak, Fire or Accident California Poison Control System: (800) 356-3129
 Call CHEMTREC
 North America: (800)424-9300
 Others: (703)527-3887 (collect)

Health Hazards/Precautionary Measures: Avoid contact with eyes, skin and clothing. Wash thoroughly after handling.

Physical Hazards/Precautionary Measures: Keep away from all sources of ignition.

Appearance: Clear and bright
Physical form: Liquid
Odor: Mild petroleum

NFPA Hazard Class:

Health: 1 (Slight)
 Flammability: 1 (Slight)
 Reactivity: 0 (Least)

HMIS Hazard Class

Health: 1 (Slight)
 Flammability: 1 (Slight)
 Physical Hazard: 0 (Least)

2. COMPOSITION/INFORMATION ON INGREDIENTS

<u>HAZARDOUS COMPONENTS</u>	<u>%WEIGHT</u>	<u>EXPOSURE GUIDELINE</u>		
		<u>Limits</u>	<u>Agency</u>	<u>Type</u>
Zinc Compound CAS# Proprietary	<1	Not Established		

<u>OTHER COMPONENTS</u>	<u>% WEIGHT</u>	<u>EXPOSURE GUIDELINE</u>		
		<u>Limits</u>	<u>Agency</u>	<u>Type</u>
Lubricant Base Oil (Petroleum) CAS# Various	>99	(See: Oil Mist, If Generated)		
Additives CAS# Proprietary	<1	Not Established		

<u>REFERENCE</u>	<u>EXPOSURE GUIDELINE</u>		
	<u>Limits</u>	<u>Agency</u>	<u>Type</u>
Oil Mist, If Generated CAS# None	5 mg/m3	ACGIH	TWA
	10 mg/m3	ACGIH	STEL
	5 mg/m3	OSHA	TWA
	2500 mg/m3	NIOSH	IDLH
	5 mg/m3	NOHSC	TWA

The base oil for this product can be a mixture of any of the following highly refined petroleum streams:
CAS 64741-88-4; CAS 64741-89-5; CAS 64741-96-4; CAS 64741-97-5; CAS 64742-01-4; CAS 64742-52-5; CAS
64742-53-6; CAS 64742-54-7; CAS 64742-55-8; CAS 64742-56-9; CAS 64742-57-0; CAS 64742-62-7; CAS
64742-63-8; CAS 64742-65-0; CAS 72623-85-9; CAS 72623-86-0; CAS 72623-87-1

Note: State, local or other agencies or advisory groups may have established more stringent limits.
Consult an industrial hygienist or similar professional, or your local agencies, for further information.

1%=10,000 PPM.

All components are listed on the TSCA inventory.

3. HAZARDS IDENTIFICATION

Potential Health Effects:

Eye: Contact may cause mild eye irritation including stinging, watering, and redness.

Skin: Contact may cause mild skin irritation including redness, and a burning sensation. Prolonged or repeated contact can worsen irritation by causing drying and cracking of the skin leading to dermatitis (inflammation). No harmful effects from skin absorption are expected.

Inhalation (Breathing): No information available. Studies by other exposure routes suggest a low degree of toxicity by inhalation.

Ingestion (Swallowing): No harmful effects expected from ingestion.

Signs and Symptoms: Effects of overexposure may include irritation of the nose and throat, irritation of the digestive tract, nausea and diarrhea.

Cancer: Inadequate evidence available to evaluate the cancer hazard of this material. See Section 11 for carcinogenicity information of individual components, if any.

Target Organs: No data available for this material.

Developmental: No data available for this material.

(MSDS: 722330)

Page 3 of 7

Pre-Existing Medical Conditions: Conditions aggravated by exposure may include skin disorders.

4. FIRST AID MEASURES

Eye: If irritation or redness develops, move victim away from exposure and into fresh air. Flush eyes with clean water. If symptoms persist, seek medical attention.

Skin: Wipe material from skin and remove contaminated shoes and clothing. Cleanse affected area(s) thoroughly by washing with mild soap and water and, if necessary, a waterless skin cleanser. If irritation or redness develops and persists, seek medical attention.

Inhalation (Breathing): If respiratory symptoms develop, move victim away from source of exposure and into fresh air. If symptoms persist, seek medical attention. If victim is not breathing, clear airway and immediately begin artificial respiration. If breathing difficulties develop, oxygen should be administered by qualified personnel. Seek immediate medical attention.

Ingestion (Swallowing): First aid is not normally required; however, if swallowed and symptoms develop, seek medical attention.

Note To Physicians: High-pressure hydrocarbon injection injuries may produce substantial necrosis of underlying tissue despite an innocuous appearing external wound. Often these injuries require extensive emergency surgical debridement and all injuries should be evaluated by a specialist in order to assess the extent of injury.

5. FIRE FIGHTING MEASURES

Flammable Properties:

- Flash Point: >384°F/>196°C (COC)
- OSHA Flammability Class: Not applicable
- LEL/UEL%: No Data
- Autoignition Temperature: No Data

Unusual Fire & Explosion Hazards: This material may burn, but will not ignite readily. If container is not properly cooled, it can rupture in the heat of a fire.

Extinguishing Media: Dry chemical, carbon dioxide, foam, or water spray is recommended. Water or foam may cause frothing of materials heated above 212°F. Carbon dioxide can displace oxygen. Use caution when applying carbon dioxide in confined spaces.

Fire Fighting Instructions: For fires beyond the incipient stage, emergency responders in the immediate hazard area should wear bunker gear. When the potential chemical hazard is unknown, in enclosed or confined spaces, or when explicitly required by DOT, a self contained breathing apparatus should be worn. In addition, wear other appropriate protective equipment as conditions warrant (see Section 8).

Isolate immediate hazard area, keep unauthorized personnel out. Stop spill/release if it can be done with minimal risk. Move undamaged containers from immediate hazard area if it can be done with minimal risk.

Water spray may be useful in minimizing or dispersing vapors and to protect personnel. Cool equipment exposed to fire with water, if it can be done with minimal risk. Avoid spreading burning liquid with water used for cooling purposes.

6. ACCIDENTAL RELEASE MEASURES

This material may burn, but will not ignite readily. Keep all sources of ignition away from spill/release. Stay upwind and away from spill/release. Notify persons down wind of the spill/release, isolate immediate hazard area and keep unauthorized personnel out. Stop spill/release if it can be done with minimal risk. Wear appropriate protective equipment including respiratory protection as conditions warrant (see Section 8).

Prevent spilled material from entering sewers, storm drains, other unauthorized drainage systems, and natural waterways. Dike far ahead of spill for later recovery or disposal. Spilled material may be absorbed into an appropriate absorbent material.

Notify fire authorities and appropriate federal, state, and local agencies. Immediate cleanup of any spill is recommended. If spill of any amount is made into or upon navigable waters, the contiguous zone, or adjoining shorelines, notify the National Response Center (phone number 800-424-8802).

7. HANDLING AND STORAGE

Handling: Do not enter confined spaces such as tanks or pits without following proper entry procedures such as ASTM D-4276 and 29CFR 1910.146. The use of appropriate respiratory protection is advised when concentrations exceed any established exposure limits (see Sections 2 and 8).

Do not wear contaminated clothing or shoes. Use good personal hygiene practices.

High pressure injection of hydrocarbon fuels, hydraulic oils or greases under the skin may have serious consequences even though no symptoms or injury may be apparent. This can happen accidentally when using high pressure equipment such as high pressure grease guns, fuel injection apparatus or from pinhole leaks in tubing of high pressure hydraulic oil equipment.

"Empty" containers retain residue and may be dangerous. Do not pressurize, cut, weld, braze, solder, drill, grind, or expose such containers to heat, flame, sparks, or other sources of ignition. They may explode and cause injury or death. "Empty" drums should be completely drained, properly bunged, and promptly shipped to the supplier or a drum reconditioner. All containers should be disposed of in an environmentally safe manner and in accordance with governmental regulations.

Before working on or in tanks which contain or have contained this material, refer to OSHA regulations, ANSI Z49.1 and other references pertaining to cleaning, repairing, welding, or other contemplated operations.

Storage: Keep container(s) tightly closed. Use and store this material in cool, dry, well-ventilated areas away from heat and all sources of ignition. Store only in approved containers. Keep away from any incompatible material (see Section 10). Protect container(s) against physical damage.

8. EXPOSURE CONTROLS/PERSONAL PROTECTION

Engineering controls: If current ventilation practices are not adequate to maintain airborne concentrations below the established exposure limits (see Section 2), additional engineering controls may be required.

Personal Protective Equipment (PPE):

Respiratory: A NIOSH certified air purifying respirator with a Type 95 (R or P) particulate filter may be used under conditions where airborne concentrations are expected to exceed exposure limits (see Section 2).

Protection provided by air purifying respirators is limited (see manufacturer's respirator selection guide). Use a NIOSH approved self-contained breathing apparatus (SCBA) or equivalent operated in a pressure demand or other positive pressure mode if there is potential for an uncontrolled release, exposure levels are not known, or any other circumstances where air purifying respirators may not provide adequate protection. A respiratory protection program that meets OSHA's 29 CFR 1910.134 and ANSI Z88.2 requirements must be followed whenever workplace conditions warrant a respirator's use.

Skin: The use of gloves impervious to the specific material handled is advised to prevent skin contact and possible irritation (see manufacturers literature for information on permeability).

Eye/Face: Approved eye protection to safeguard against potential eye contact, irritation, or injury is recommended. Depending on conditions of use, a face shield may be necessary.

(MSDS: 722330)

Page 5 of 7

Other Protective Equipment: A source of clean water should be available in the work area for flushing eyes and skin. Impervious clothing should be worn as needed.

Suggestions for the use of specific protective materials are based on readily available published data. Users should check with specific manufacturers to confirm the performance of their products.

9. PHYSICAL AND CHEMICAL PROPERTIES

Note: Unless otherwise stated, values are determined at 20°C (68°F) and 760 mm Hg (1 atm).

Appearance: Clear and bright

Physical State: Liquid

Odor: Mild petroleum

pH: Not applicable

Vapor Pressure (mm Hg): <1

Vapor Density (air=1): >1

Boiling Point/Range: No Data

Freezing/Melting Point: <-27°F / <-33°C

Solubility in Water: Negligible

Specific Gravity: 0.855-0.871

Percent Volatile: Negligible

Evaporation Rate (nBuAc=1): Negligible

Viscosity: 22-68 cSt @ 40°C / 4.3-8.7 cSt @ 100°C

Bulk Density: 7.13-7.26 lb/gal

Flash Point: >384°F / >196°C (COC)

Flammable/Explosive Limits (%): No Data

10. STABILITY AND REACTIVITY

Stability: Stable under normal ambient and anticipated storage and handling conditions of temperature and pressure.

Conditions To Avoid: Extended exposure to high temperatures can cause decomposition.

Materials to Avoid (Incompatible Materials): Avoid contact with strong oxidizing agents.

Hazardous Decomposition Products: Combustion can yield carbon, nitrogen, sulfur, phosphorus, and zinc oxides.

Hazardous Polymerization: Will not occur.

11. TOXICOLOGICAL INFORMATION

Lubricant Base Oil (Petroleum) (CAS# Various)

Carcinogenicity: The petroleum base oils contained in this product have been highly refined by a variety of processes including solvent extraction, hydrotreating, and dewaxing to remove aromatics and improve performance characteristics. None of the oils used are listed as a carcinogen by NTP, IARC, or OSHA.

12. ECOLOGICAL INFORMATION

Not evaluated at this time

13. DISPOSAL CONSIDERATIONS

This material under most intended uses would become used oil due to contamination by physical or chemical impurities. RECYCLE ALL USED OIL. While being recycled, used oil is regulated by 40 CFR 279. Use resulting in chemical or physical change or contamination may also subject it to regulation as hazardous waste. Under federal regulations, used oil is a solid waste managed under 40 CFR 279. However, in California, used oil is managed as hazardous waste until tested to show it is not hazardous. Consult state and local regulations regarding the proper handling of used oil. In the case of used oil, the intent to discard it may cause the used oil to be regulated as hazardous waste.

Contents should be completely used and containers emptied prior to discard. Rinsate may be considered a RCRA hazardous waste and must be disposed of with care and in compliance with federal, state and local regulations. Large empty containers, such as drums, should be returned to the distributor or a drum reconditioner. To assure proper disposal of small empty containers, consult with state and local regulations and disposal authorities.

14. TRANSPORT INFORMATION

DOT Shipping Description: Not classified as hazardous

15. REGULATORY INFORMATION

EPA SARA 311/312 (Title III Hazard Categories):

Acute Health: No
Chronic Health: No
Fire Hazard: No
Pressure Hazard: No
Reactive Hazard: No

SARA 313 and 40 CFR 372:

This material contains the following chemicals subject to the reporting requirements of SARA 313 and 40 CFR 372:

Component	CAS Number	Weight %
Zinc Compound	Proprietary	<1

California Proposition 65:

Warning: This material contains the following chemicals which are known to the State of California to cause cancer, birth defects or other reproductive harm, and are subject to the requirements of California Proposition 65 (CA Health & Safety Code Section 25249.5):

--None Known--

Carcinogen Identification:

This material has not been identified as a carcinogen by NTP, IARC, or OSHA. See Section 11 for carcinogenicity information of individual components, if any.

EPA (CERCLA) Reportable Quantity:

--None--

Canada - Domestic Substances List: Listed

WHMIS Class:

Not regulated

This product has been classified in accordance with the hazard criteria of the Controlled Products Regulations (CPR) and the MSDS contains all the information required by the CPR.

16. OTHER INFORMATION

Issue Date: 02/06/03

(MSDS: 722330)

Page 7 of 7

Previous Issue Date: 01/01/02
Product Code: 4641032000, 4642046000, 4643068000
Revised Sections: New Format
Previous Product Code: 4641032000
MSDS Number: 722330
Status: Final

Disclaimer of Expressed and Implied Warranties:

The information presented in this Material Safety Data Sheet is based on data believed to be accurate as of the date this Material Safety Data Sheet was prepared. **HOWEVER, NO WARRANTY OF MERCHANTABILITY, FITNESS FOR ANY PARTICULAR PURPOSE, OR ANY OTHER WARRANTY IS EXPRESSED OR IS TO BE IMPLIED REGARDING THE ACCURACY OR COMPLETENESS OF THE INFORMATION PROVIDED ABOVE, THE RESULTS TO BE OBTAINED FROM THE USE OF THIS INFORMATION OR THE PRODUCT, THE SAFETY OF THIS PRODUCT, OR THE HAZARDS RELATED TO ITS USE.** No responsibility is assumed for any damage or injury resulting from abnormal use or from any failure to adhere to recommended practices. The information provided above, and the product, are furnished on the condition that the person receiving them shall make their own determination as to the suitability of the product for their particular purpose and on the condition that they assume the risk of their use. In addition, no authorization is given nor implied to practice any patented invention without a license.

This page left intentionally blank.

 **CLIMAX**

 **BORTECH**  **CALDER** **H&S** **TOOL**